

1. Features

- RGB, Ambient Light and IR Sensor
 - Low Power Management
 - I2C Fast Mode Interface Compatible
- Color Temperature and Ambient Light Sensing
 - UV/IR blocking filters
 - Programmable Gain & Integration Time
 - 16 Bit resolution
- Ideal for Operation Behind Dark Glass
 - Very High Sensitivity
- Proximity Detection with an Integrated LED Driver
- Proximity Detection
 - Programmable Offset Control Register
 - Programmable Analog Gain and Integration Time
 - Current Sink Driver for External IR LED
- Power Management
 - Low Power 1uA Sleep State
 - 100uA Wait State with Programmable Wait Time from 3ms to 10seconds
- I2C Interface Compatible
 - Up to 400kHz (I2C Fast Mode)
 - Device address : 7'b0111_001(R/W)

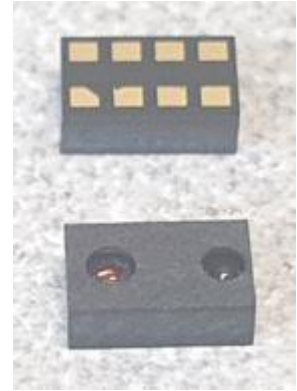

2. Applications

- Ambient Light Sensing
- Color Temperature Sensing
- Cell Phone Touch Screen Disable
- Mechanical Switch Replacement
- Automatic Speakerphone Enable
- Automatic Menu Popup

4. Specifications

4.1 Absolute Maximum Ratings

SYMBOL	PARAMETER	MIN	MAX	UNIT
VDD	Power Supply Voltage	-0.5	3.6	V
Vin	Input Voltage	-0.5	VDD	V
Vout	Output Voltage	-0.5	VDD	V
Vhbm	Static Discharge (HBM)		2000	V
Vmm	Static Discharge (MM)		200	V
Tj	Junction Temperature	-40	85	°C

4.2 Recommended Operating Conditions

SYMBOL	PARAMETER	MIN	TYP	MAX	UNIT
VDD	Power Supply Voltage	2.5	3	3.6	V
Vin	Input Voltage	0		VDD	V
Vout	Output Voltage	0		VDD	V
TA	Operating ambient temperature	-20		70	°C

4.3 Electrical Characteristics (VDD = 3V, Ta = 25°C)

PARAMETER	TEST CONDITIONS	MIN	TYP	MAX	UNIT
Supply Current	Active – LDR pulses off		250	300	uA
	Wait state		100	120	
	Sleep state		1	10	
INT,SDA output low voltage	3mA sink current 6mA sink current	0 0		0.4 0.6	V
Low Level Input Voltage				0.3*VDD	V
High Level Input Voltage		0.7*VDD			V

4.4 Data Transmission Timing Requirements

PARAMETER	CONDITIONS	MIN	MAX	UNIT
Output Low Level (SDA)	IOL = 4mA		0.5	V
SCL Operating Frequency			400	kHz
Stop and Start Condition		1.3		us
Hold Time After Repeated Start Conditions		0.6		us
SCL Clock Low Period		1.3		us
SCL Clock High Period		0.6		us
Repeated Start Condition Setup Time		0.6		us
Data Hold Time		0	0.9	us
Data Setup Time		100		ns
Clock/Data Fall Time			300	ns
Clock/Data Rise Time			300	ns
Stop Condition Setup Time		0.6		us

4.5 RGBC+IR Characteristics (VDD = 3V, Ta = 25°C, PEN = 1)

PARAMETER		TEST CONDITIONS	MIN	TYP	MAX	UNIT
Peak_ Sensitivity Wavelength of ADC	R	-	-	620	-	nm
	G	-	-	550	-	nm
	B	-	-	490	-	nm
	C	-	-	580	-	nm
	IR	-	-	850	-	nm
Counter Value of ADC	R	Integration Time 0.83ms @ 1300Lux 3000K (In wafer)		TBD		counts
	G			TBD		counts
	B			TBD		counts
	C			TBD		counts
	IR			TBD		counts
Dark Count Value		Dark Integration Time 25ms @ Dark (In wafer)	0	1	3	counts
ADC count Range		-	0	-	65535	counts
Gain scaling		GAIN_RGBC = 0 (Low) GAIN_RGBC = 1 (Med) GAIN_RGBC = 2 (High) GAIN_RGBC = 3 (Max)	-	1 1.8 3.1 6.9	-	x

4.6 Proximity Characteristics (VDD = 3V, Ta = 25°C, PEN = 1)

PARAMETER	TEST CONDITIONS		MIN	TYP	MAX	UNIT
Prox. Full count value					65535	counts
LED drive current	PDL = 0	PDRIVE = 0		215		mA
		PDRIVE = 1		182		
PDRIVE = 2			145			
PDRIVE = 3			100			
LED drive current	PDL = 1	PDRIVE = 0		25		mA
		PDRIVE = 1		20		
		PDRIVE = 2		15		
		PDRIVE = 3		10		
Gain scaling	GAIN_PS = 0 (Low) GAIN_PS = 1 (Med) GAIN_PS = 2 (High)			1 1.8 3.1		x

4.7 Typical Performance Characteristics

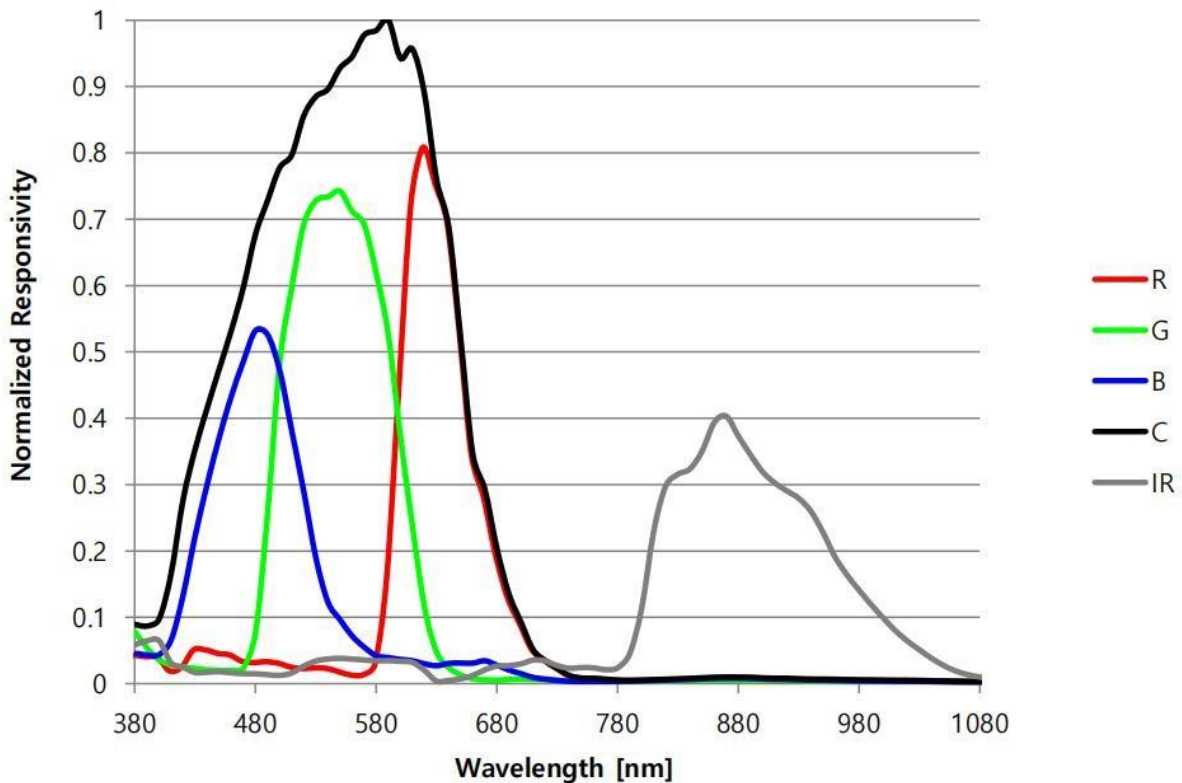

5. Function Block Diagram

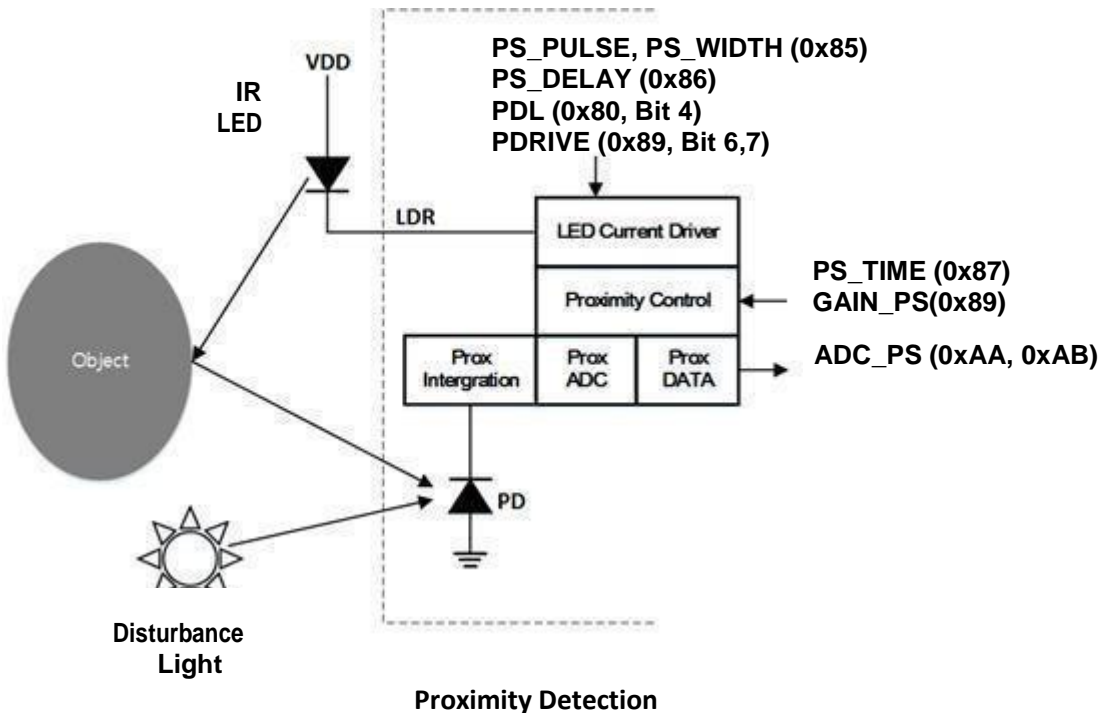
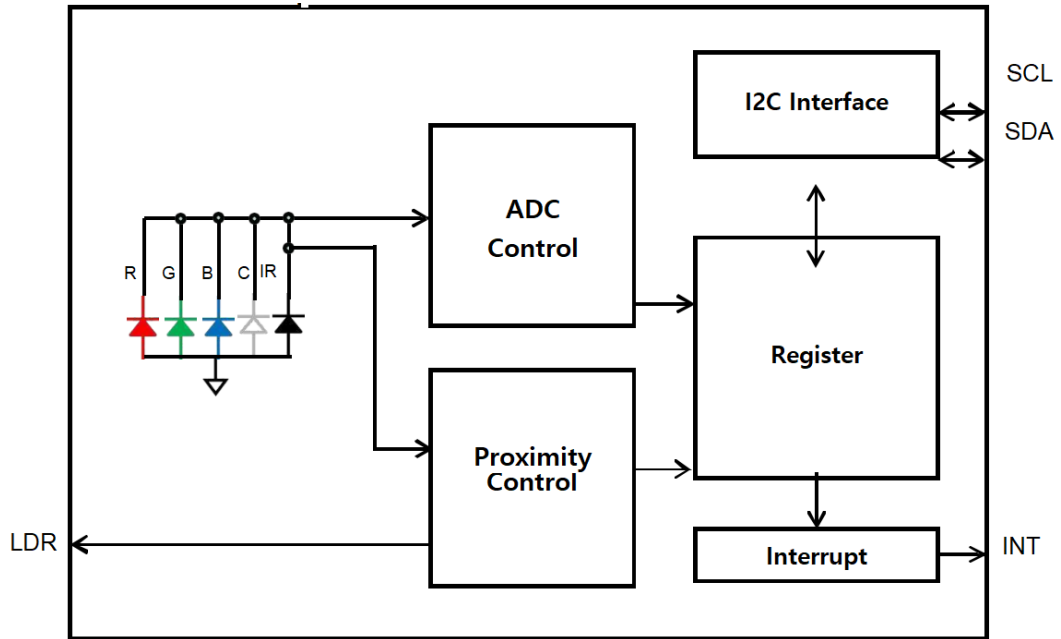

6. Typical Application

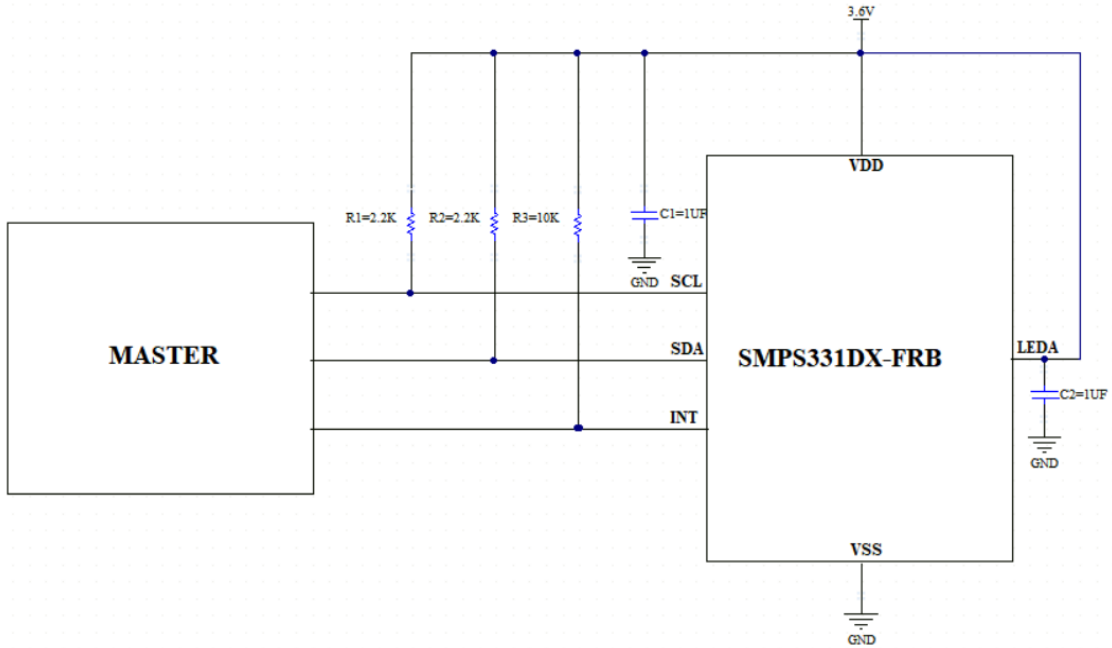

7. Package Dimension

Units [mm]

