

DATASHEET & RELIABILITY DATA

TS5 SERIES

(주)오디피

Open Digital Power Corp.

Contents

- Introduction	-----	3~4 page
- Datasheet	-----	5~8 page
1. Internal Circuit Architecture		
2. Maximum Ratings		
3. Electrical Characteristics		
4. Isolation Characteristics		
5. General Characteristics		
6. Environment		
- Reliability Data	-----	9~19 page
1. MTBF		
2. Life Time		
3. Environmental Stress Test		
4. Main Components Δt Test		
5. Derating of semiconductor(Bridge Diode, FET, Rectifier diode)		
6. Abnormal Test		
- Application Sheet	-----	20~25 page
1. Basic Connection		
2. EMI(Electro Magnetic Interference) Connection		
3. Output Section		
4. Protection		
5. Operating Method		
6. Environment		
7. Isolation		
8. Outline Dimensions		

MAX. Power 5W Isolated On-Board Type AC-DC Converter

TS5 Series Isolated On-Board Type AC-DC Converter



Features

- Power Saving Mode Operation
- High Efficiency
- Isolated Input - Output
- 115kHz fixed frequency and Current mode Control
- Low output Ripple & Noise
- Built-in over current protection circuit
- Short Circuit Protection
- Universal Input Voltage(Free Voltage)
- Safety standard : CB, CE approved (CB : IEC60950-1, CE : EN60950-1)
- RoHS compatible design

Applications

- Data and telecommunication
- FA control
- Datacommunication electronic equipments

Environment

- Operating Temperature : -40℃ ~ 70℃
- Operating Humidity : 20% ~ 90% RH (Non condensing)
- Storage Temperature : -40℃ ~ 85℃
- Cooling : Free-Air Convection
- MTBF : 5.0 x 10⁵ hrs

Model Name Structure

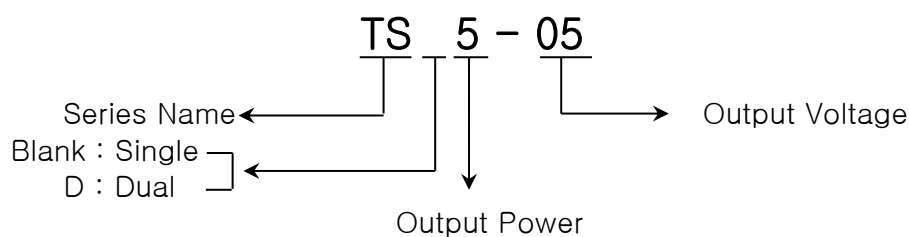

Pin assignments & Function

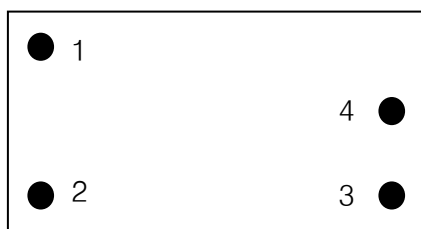

<Top View>

- Single Output Name & Function

PIN No.	Single
1	AC input N
2	AC input L
3	+ Vout
4	- Vout

– Datasheet

1. Internal Circuit Architecture

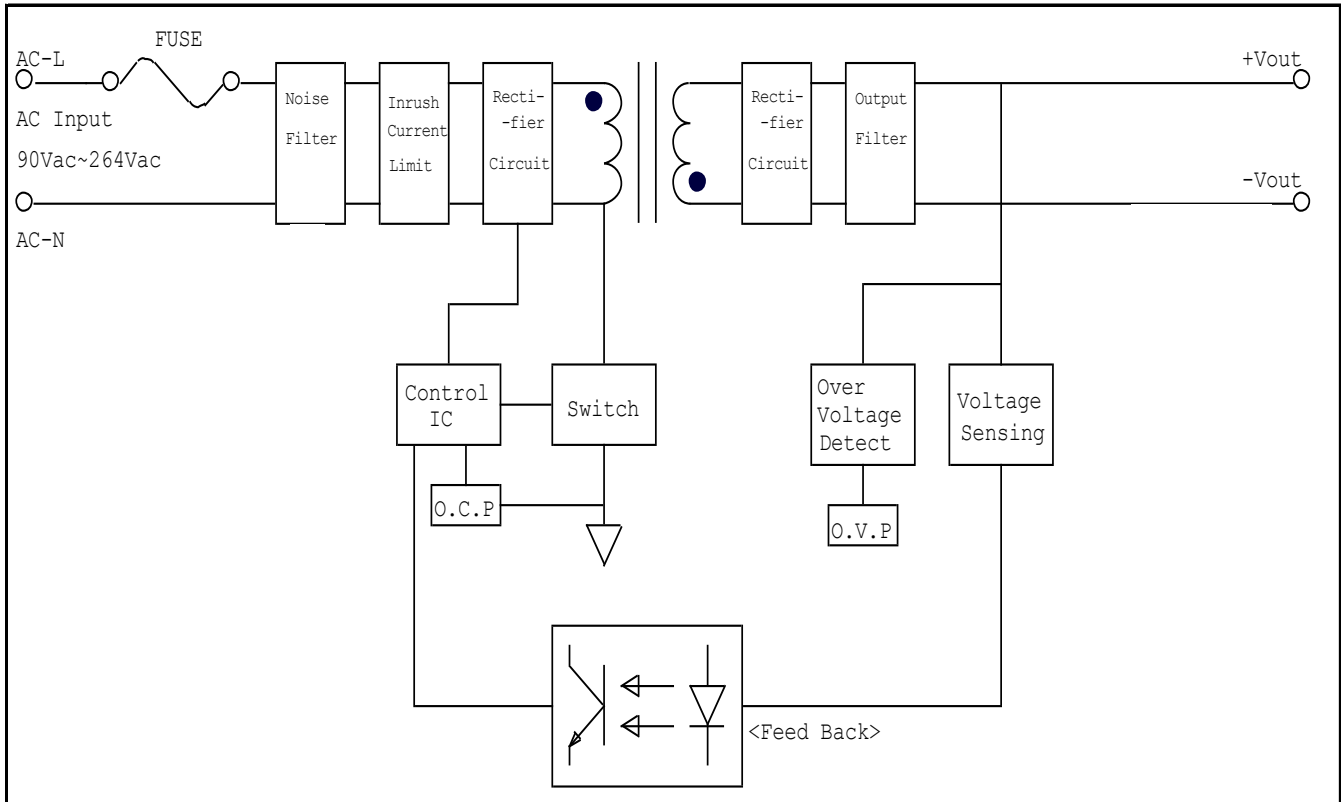

2. Maximum Ratings

Characteristics		Symbol	Min.	Typ.	Max.	Unit
No-load Power Consumption	TS5 - XX				0.1	W
Frequency	TS5 - XX		44	-	440	Hz
Input Voltage Continuous	TS5 - 05	Vin	90	-	264	Vac
	TS5 - 12		90	-	264	
	TS5 - 15		90	-	264	
	TS5 - 24		90	-	264	
Operating Ambient Temperature		Ta	-40	-	70	°C
Storage Temperature		Tstg	-40	-	85	°C
Withstand Voltage (Input - Output)			-	-	3000	Vac

3. Electrical Characteristics

– Input Section

Ta : 25°C, Vin : Typical Input Voltage

Characteristics		Symbol	Min.	Typ.	Max.	Unit
No-load Power Consumption	TS5 – XX				0.1	W
Operating Voltage Range	TS5 – XX	Vin	90	110, 220	264	Vac
Frequency	TS5 – XX		44	50, 60	440	Hz
Max. Input Current (Vin : rated, Io : 100%)	TS5 – XX	Iin		0.13		A
Max. No Load Input Current (Vin : min.)	TS5 – XX				2.5	mA
Inrush Current (In : 220Vac)	TS5 – XX				30	A
Leakage Current (In : 220Vac)	TS5 – XX				0.35	mA

– Output Section

Ta : 25°C, Vin : Minimum, Typical, Maximum Input Voltage

Characteristics		Symbol	Min.	Typ.	Max.	Unit
Output Voltage Accuracy	Single	Vo	–	–	±2	%
			–	–		
Regulation	Line Regulation (From min. Vin to max. Vin, constant load)		–	–	±1	%
	Load Regulation (From no load to maximum load)		–	–	±1	%(@Single)
Output Ripple and Noise (Vin : Rated, Io : Max., BW : 20MHz)		mVp-p	–	–	1% of Vout	mV (peak to peak)

Characteristics		Symbol	Min.	Typ.	Max.	Unit
Output Current	TS5 - 05	I _o	-	-	1.0	A
	TS5 - 12		-	-	0.42	
	TS5 - 15		-	-	0.34	
	TS5 - 24		-	-	0.21	
Output Current Limit (OCP : Over Current Protection, recovers automatically)			105	-	-	%
Dynamic Load Response (V _{in} : rated, I _o : from 10% to 100%, from 100% to 10%, BW : 20MHz, Freq. : 100Hz, Duty : 0.5, Tr/Tf : 100us)			-	-	3% of V _{out}	mV (peak to peak)
Start - Up Time		T _{start}			100	ms
Turn - on Overshoot			-	-	5	%
Efficiency (V _{in} : Rated, I _o : Max.)	TS5 - 05		-	75	-	%
	TS5 - 12		-	77	-	
	TS5 - 15		-	78	-	
	TS5 - 24		-	80	-	

4. Isolation Characteristics

Characteristics		Symbol	Min.	Typ.	Max.	Unit
Withstand Voltage	Input - Output		-	-	3000	V _{ac}
Isolation Resistance (DC500V at 25°C and 70%RH)	Input - Output	R _{iso}	100	-	-	MΩ

5. General Characteristics

Characteristics	Symbol	Min.	Typ.	Max.	Unit
Remote on / off control (CNT Pin, Negative Logic Module on : Logic Low or Short to -Vin Module off : Logic High or open)	CNT				
External Trim Adj. Range (TRM Pin, Vout variation by external parts)	TRM				
Switching Frequency			115		kHz
MTBF (MIL-HDBK-217F)		5.0 x 10 ⁵			hrs
Dimension (L x W x H)		58.0 x 30.0 x 19.0			mm
Weight		-	-	50	grams

6. Environment

Characteristics	Symbol	Min.	Typ.	Max.	Unit
Operating Temperature Range	Ta	-40	-	70	°C
Operating Humidity (non Condensing)		20	-	90	%RH
Storage Temperature	Tstg	-40	-	85	°C

- Reliability Data

1. MTBF

Calculating Reliable Values of MTBF

Calculated based on part count reliability projection of MIL-HDBK-217F individual failure rates λ_g is given to each part and MTBF is calculated by the count of each part.

Method is :

$$MTBF = \frac{10^6}{\sum_{i=1}^n Ni(\lambda_g \cdot \pi Q)_i} = \frac{10^6}{\lambda_{equip}} \quad [\text{hours}]$$

For a given equipment environment where :

λ_{equip} = Total equipment failure rate (Failures / 10⁶ Hours)

λ_g = Generic failure rate for the i th generic part (Failures / 10⁶ Hours)

πQ = Quality factor for the i th generic part ($\pi Q = 1$)

Ni = Quantity of i th generic part

n = Number of different generic part categories in the equipment

	PART	Number	Failure Rate	Failure Rate
1	Logic IC	2	0.015	0.0300000
2	FET	1	0.012	0.0120000
3	Voltage Regulaor	1	0.002	0.0020000
4	Diode (Zener)	1	0.002	0.0020000
5	Diode (FRD)	2	0.069	0.1380000
6	Diode (SBD)	1	0.027	0.0270000
7	Bridge Diode	1	0.066	0.0660000
8	LED	0	0.00023	-
9	Varistor	0	0.0013	-
10	Photo-coupler	1	0.07	0.0700000
11	Thyristor	0	0.0022	-
12	Elec.- Cap.	5	0.019	0.0950000
13	Ceramic Cap.	2	0.026	0.0520000
14	MLCC	5	0.053	0.2650000
15	Choke coil	3	0.00022	0.0006600
16	Switching transformer	1	0.0042	0.0042000
17	Line Filter	0	0.0044	-
18	Resistor	12	0.0024	0.0288000
19	Resistor Variable	0	0.0024	-
20	Thermister	1	0.0019	0.0019000
21	Connertor	0	0.052	-
22	Soldering Point	104	0.0078	0.8112000
23	PCB	1	0.37	0.3700000
24	Fuse	1	0.01	0.0100000
Total Equipment Failure Rate (λ_{equip})				1.9857600
MTBF = 10 ⁶ / λ_{equip} (F/T)				503,585.529
MTBF ≅ 500,000[Hours]				

2. Lifetime

The shortest lifetime parts is an electrolytic capacitor. Thus, the lifetime of SMPS is lifetime of electrolytic capacitors.

Lifetime of electrolytic capacitor can be calculated by the following factors.

- T_0 : Load life rating
- T_{max} : Maximum temperature rating of capacitor
- T_{case} : Temperature of case

$$T[\text{hour}] = T_0 * 2^{\frac{T_{max} - T_{case}}{10}}$$

T : Life Time(Electrolytic Cap.)
 T_0 : Load Life Rating
 T_{max} : Max. Temperature rating of capacitor
 T_{case} : Temperature of case

TS5-05 <(5VDC, 1A(100% Load)>, [unit : hrs]			
110Vac Input		220Vac Input	
$T_{amb.} : 25^{\circ}\text{C}$	$T_{amb.} : 50^{\circ}\text{C}$	$T_{amb.} : 25^{\circ}\text{C}$	$T_{amb.} : 50^{\circ}\text{C}$
> 100,000 hrs	32,500 hrs	> 100,000 hrs	39,000 hrs

TS5-12 <(12VDC, 0.42A(100% Load)>, [unit : hrs]			
110Vac Input		220Vac Input	
$T_{amb.} : 25^{\circ}\text{C}$	$T_{amb.} : 50^{\circ}\text{C}$	$T_{amb.} : 25^{\circ}\text{C}$	$T_{amb.} : 50^{\circ}\text{C}$
> 100,000 hrs	34,000 hrs	> 100,000 hrs	45,000 hrs

TS5-15 <(15VDC, 0.34A(100% Load)>, [unit : hrs]			
110Vac Input		220Vac Input	
$T_{amb.} : 25^{\circ}\text{C}$	$T_{amb.} : 50^{\circ}\text{C}$	$T_{amb.} : 25^{\circ}\text{C}$	$T_{amb.} : 50^{\circ}\text{C}$
> 100,000 hrs	36,500 hrs	> 100,000 hrs	47,000 hrs

TS5-24 <(24VDC, 0.21A(100% Load)>, [unit : hrs]			
110Vac Input		220Vac Input	
$T_{amb.} : 25^{\circ}\text{C}$	$T_{amb.} : 50^{\circ}\text{C}$	$T_{amb.} : 25^{\circ}\text{C}$	$T_{amb.} : 50^{\circ}\text{C}$
> 100,000 hrs	38,500 hrs	> 100,000 hrs	48,500 hrs

3. Environmental Stress Test(EST)

The purpose of the environment stress test is to ensure reliability by setting in advance the following environment and verified.

- transport process and conservation status
- environmental change conditions that can be applied to the product from the process of the end-user

Test cycle consists of 10 segments(total 100 hours). Test results of all segments must meet the specifications. (refer to Fig.1 & Table1)

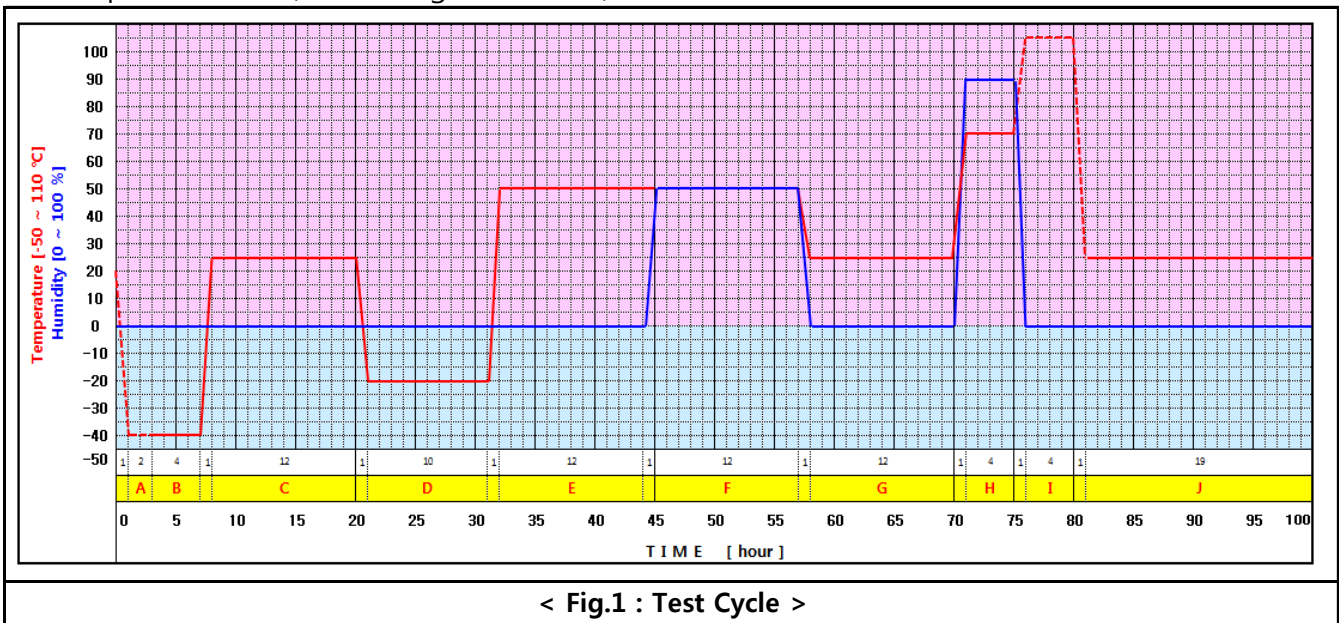

< Fig.1 : Test Cycle >

Segment	Time	Temp.	Humidity	Description	Input 'SW'
A	2 hours	-40°C	0%	Low temperature storage	off
B	4 hours	-40°C	0%	Low temperature operation	on
C	12 hours	25°C	0%	Room temperature operation	on
D	10 hours	-20°C	0%	Low temperature operation	on
E	12 hours	50°C	0%	High temperature operation	on
F	12 hours	50°C	50%	High-temperature & humidity operation	on
G	12 hours	25°C	0%	Room temperature operation	on
H	4 hours	70°C	90%	High-temperature & humidity operation	on
I	4 hours	105°C	0%	High temperature storage	off
J	19 hours	25°C	0%	Room temperature operation	on

< Table1 : Segment Description >

3.1. Environmental Stress Test Results

- a. Test Sample : TS5-15
- b. 100 hours in one cycle test graph

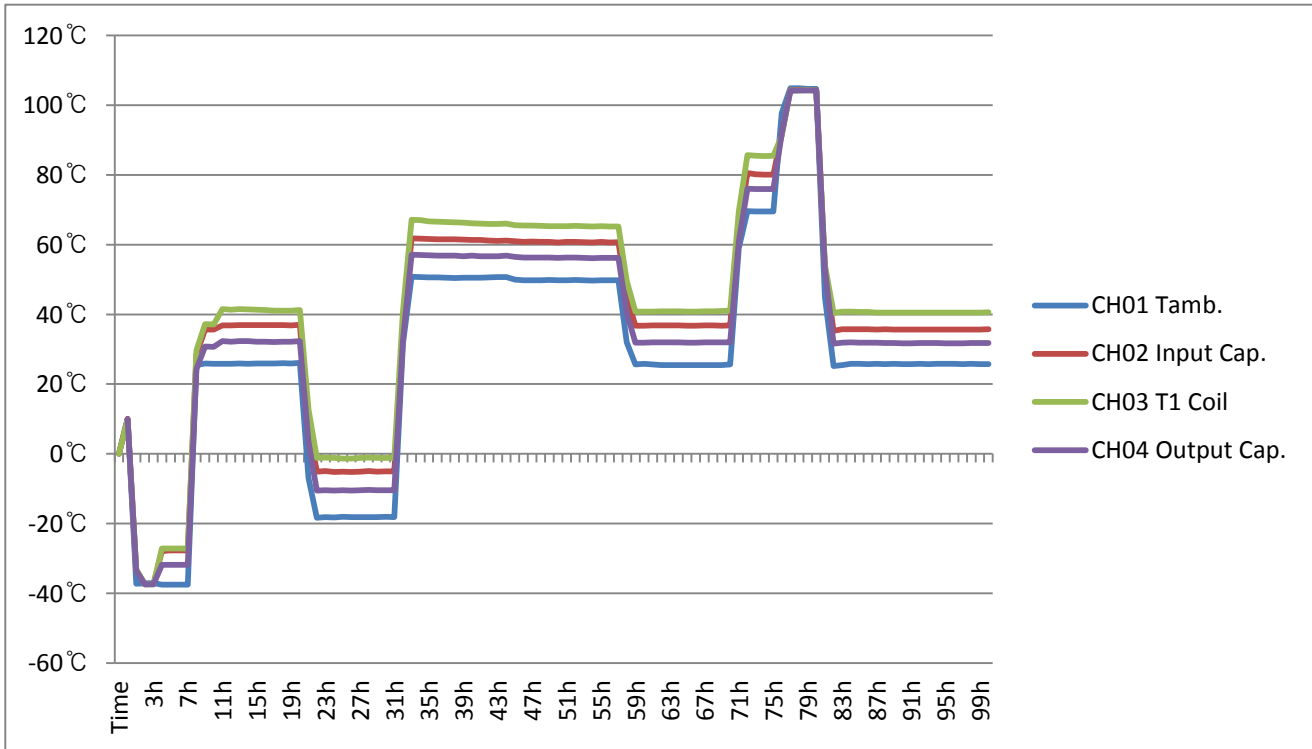

c. Characteristics test results (@ Input Voltage : 220Vac)

Segment	Test Time	T _{amb./Humi.}	Output Voltage	Start up	Ripple / Noise	Output Load Condition
A	3h	-40°C / 0%	14.71V	OK	183 / 183 [mVp-p]	50% Load
B	10h	25°C / 0%	15.04V	OK	11 / 23 [mVp-p]	100% Load
C	24h	-20°C / 0%	15.1V	OK	28 / 36 [mVp-p]	100% Load
D	33h	50°C / 0%	15.01V	OK	9 / 23 [mVp-p]	100% Load
E	48h	50°C / 50%	15.01V	OK	9 / 25 [mVp-p]	100% Load
F	57h	25°C / 0%	15.04V	OK	9 / 26 [mVp-p]	100% Load
G	72h	70°C / 90%	14.98V	OK	9 / 55 [mVp-p]	100% Load
H	81h	25°C / 0%	15.08V	OK	9 / 26 [mVp-p]	100% Load
I	100h	25°C / 0%	15.06V	OK	10 / 27 [mVp-p]	100% Load
Test Result			Pass	Pass	Pass	

4. Main Components Δt Test

The purpose of the test is to ensure the reliability and margin by measuring the heating value of the main components.

4.1. TS5-05 (@ 100% Load)

Test Point \ Test Condition	Vin : 110Vac, 60Hz		Vin : 220Vac, 60Hz	
	T _{amb.}	29.2°C	T _{amb.}	29.7°C
	T _c	Δt	T _c	Δt
Bridge Diode	46.8°C	17.6°C	45.8°C	16.1°C
Input Cap.	57.0°C	27.8°C	55.0°C	25.3°C
PWM IC	49.1°C	19.9°C	54.9°C	25.2°C
Trans Coil	60.5°C	31.3°C	62.7°C	33.0°C
Trans Core	62.5°C	33.3°C	65.1°C	35.4°C
Output Diode	72.0°C	42.8°C	73.4°C	43.7°C

4.2. TS5-12 (@ 100% Load)

Test Point \ Test Condition	Vin : 110Vac, 60Hz		Vin : 220Vac, 60Hz	
	T _{amb.}	30.7°C	T _{amb.}	31.0°C
	T _c	Δt	T _c	Δt
Bridge Diode	46.4°C	15.7°C	46.6°C	15.6°C
Input Cap.	57.9°C	27.2°C	54.2°C	23.2°C
PWM IC	52.1°C	21.4°C	63.7°C	32.7°C
Trans Coil	64.0°C	33.3°C	67.6°C	36.6°C
Trans Core	60.3°C	29.6°C	64.0°C	33.0°C
Output Diode	62.8°C	32.1°C	64.3°C	33.3°C

4.3. TS5-15 (@ 100% Load)

Test Point \ Test Condition	Vin : 110Vac, 60Hz		Vin : 220Vac, 60Hz	
	T _{amb.}	32.6°C	T _{amb.}	32.3°C
	T _c	Δt	T _c	Δt
Bridge Diode	48.8°C	16.2°C	48.2°C	15.9°C
Input Cap.	58.8°C	26.2°C	55.0°C	22.7°C
PWM IC	52.7°C	20.1°C	63.4°C	31.1°C
Trans Coil	63.6°C	31.0°C	66.6°C	34.3°C
Trans Core	60.0°C	27.4°C	62.9°C	30.6°C
Output Diode	60.1°C	27.5°C	61.0°C	28.7°C

4.4. TS5-24 (@ 100% Load)

Test Point \ Test Condition	Vin : 110Vac, 60Hz		Vin : 220Vac, 60Hz	
	T _{amb.}	33.1°C	T _{amb.}	32.9°C
	T _c	Δt	T _c	Δt
Bridge Diode	48.6°C	15.5°C	48.9°C	16.0°C
Input Cap.	58.5°C	25.4°C	55.1°C	22.2°C
PWM IC	50.5°C	17.4°C	63.2°C	30.3°C
Trans Coil	59.6°C	26.5°C	64.3°C	31.4°C
Trans Core	58.9°C	25.8°C	63.2°C	30.3°C
Output Diode	54.7°C	21.6°C	55.9°C	23.0°C

5. Derating of Semiconductor

Compare $T_{j(max)}$ (maximum junction temperature) and T_j and is expressed as a percentage. T_j is the value calculated by the temperature of the case and the power dissipation and the thermal impedance.

- Measuring Components : Bridge Diode, FET, Rectifier diode
- Calculating method of derating ratio

$$\text{Derating Ratio} = \frac{T_j}{T_{j(max)}} \times 100 \text{ [%]}$$

$$T_j = T_c + (R_{\theta(J-C)} \times P_d)$$

T_c : Case Temperature

$R_{\theta(J-C)}$: Thermal impedance between junction and case

P_d : Power dissipation

5.1. TS5-05

Condition		Vin : 110Vac, 60Hz		Load : 100%	T _{amb.} : 50°C
Components					
BD1 (Bridge Diode)	$T_{j(max)}$: 150 °C	P_d : 0.13 W		$T_j = 85.0$ °C	Derating Ratio = 56.7%
	$R_{\theta(J-A)}$: 134 °C/W				
	T_A : 67.6°C				
IC1 (IC + FET)	$T_{j(max)}$: 150 °C	P_d : 0.07 W		$T_j = 76.9$ °C	Derating Ratio = 51.3%
	$R_{\theta(J-A)}$: 100 °C/W				
	T_A : 69.9°C				
D4 (Rectifier Diode)	$T_{j(max)}$: 125 °C	P_d : 0.5 W		$T_j = 98.8$ °C	Derating Ratio = 79.0%
	$R_{\theta(J-C)}$: 12 °C/W				
	T_c : 92.8°C				
Condition		Vin : 220Vac, 60Hz		Load : 100%	T _{amb.} : 50°C
Components					
BD1 (Bridge Diode)	$T_{j(max)}$: 150 °C	P_d : 0.05 W		$T_j = 72.8$ °C	Derating Ratio = 48.5%
	$R_{\theta(J-A)}$: 134 °C/W				
	T_A : 66.1°C				
IC1 (IC + FET)	$T_{j(max)}$: 150 °C	P_d : 0.05 W		$T_j = 80.2$ °C	Derating Ratio = 53.5%
	$R_{\theta(J-A)}$: 100 °C/W				
	T_A : 75.2°C				
D4 (Rectifier Diode)	$T_{j(max)}$: 125 °C	P_d : 0.5 W		$T_j = 99.7$ °C	Derating Ratio = 79.8%
	$R_{\theta(J-C)}$: 12 °C/W				
	T_c : 93.7°C				

5.2. TS5-12

Condition		Vin : 110Vac, 60Hz		Load : 100%	T _{amb.} : 50°C
Components					
BD1 (Bridge Diode)	T _{j(max)} : 150 °C	P _d : 0.12 W	T _j = 81.8 °C	Derating Ratio = 54.5%	
	R _{θ(J-A)} : 134 °C/W				
	T _A : 65.7°C				
IC1 (IC + FET)	T _{j(max)} : 150 °C	P _d : 0.06 W	T _j = 77.4 °C	Derating Ratio = 51.6%	
	R _{θ(J-A)} : 100 °C/W				
	T _A : 71.4°C				
D4 (Rectifier Diode)	T _{j(max)} : 175 °C	P _d : 0.33W	T _j = 86.7 °C	Derating Ratio = 49.5%	
	R _{θ(J-C)} : 14 °C/W				
	T _c : 82.1°C				
Condition		Vin : 220Vac, 60Hz		Load : 100%	T _{amb.} : 50°C
Components					
BD1 (Bridge Diode)	T _{j(max)} : 150 °C	P _d : 0.05 W	T _j = 72.3 °C	Derating Ratio = 48.2%	
	R _{θ(J-A)} : 134 °C/W				
	T _A : 65.6°C				
IC1 (IC + FET)	T _{j(max)} : 150 °C	P _d : 0.05 W	T _j = 87.7 °C	Derating Ratio = 58.5%	
	R _{θ(J-A)} : 100 °C/W				
	T _A : 82.7°C				
D4 (Rectifier Diode)	T _{j(max)} : 175 °C	P _d : 0.33W	T _j = 87.9 °C	Derating Ratio = 50.2%	
	R _{θ(J-C)} : 14 °C/W				
	T _c : 83.3°C				

5.3. TS5-15

Condition		Vin : 110Vac, 60Hz		Load : 100%	T _{amb.} : 50°C
Components					
BD1 (Bridge Diode)	T _{j(max)} : 150 °C	P _d : 0.13 W	T _j = 73.6 °C	Derating Ratio = 49.1%	
	R _{θ(J-A)} : 134 °C/W				
	T _A : 56.2°C				
IC1 (IC + FET)	T _{j(max)} : 150 °C	P _d : 0.06 W	T _j = 76.1 °C	Derating Ratio = 50.7%	
	R _{θ(J-A)} : 100 °C/W				
	T _A : 70.1°C				
D4 (Rectifier Diode)	T _{j(max)} : 175 °C	P _d : 0.27 W	T _j = 81.3 °C	Derating Ratio = 46.5%	
	R _{θ(J-C)} : 14 °C/W				
	T _c : 77.5°C				
Condition		Vin : 220Vac, 60Hz		Load : 100%	T _{amb.} : 50°C
Components					
BD1 (Bridge Diode)	T _{j(max)} : 150 °C	P _d : 0.05 W	T _j = 72.6 °C	Derating Ratio = 48.4%	
	R _{θ(J-A)} : 134 °C/W				
	T _A : 65.9°C				
IC1 (IC + FET)	T _{j(max)} : 150 °C	P _d : 0.05 W	T _j = 86.1 °C	Derating Ratio = 57.4%	
	R _{θ(J-A)} : 100 °C/W				
	T _A : 81.1°C				
D4 (Rectifier Diode)	T _{j(max)} : 175 °C	P _d : 0.27 W	T _j = 82.5 °C	Derating Ratio = 47.1%	
	R _{θ(J-C)} : 14 °C/W				
	T _c : 78.7°C				

5.4. TS5-24

Condition		Vin : 110Vac, 60Hz		Load : 100%	T _{amb.} : 50°C
Components					
BD1 (Bridge Diode)	T _{j(max)} : 150 °C	P _d : 0.11 W	T _j = 80.2 °C	Derating Ratio = 53.5%	
	R _{θ(J-A)} : 134 °C/W				
	T _A : 65.5°C				
IC1 (IC + FET)	T _{j(max)} : 150 °C	P _d : 0.06 W	T _j = 73.4 °C	Derating Ratio = 48.9%	
	R _{θ(J-A)} : 100 °C/W				
	T _A : 67.4°C				
D4 (Rectifier Diode)	T _{j(max)} : 175 °C	P _d : 0.18 W	T _j = 76.5 °C	Derating Ratio = 43.7%	
	R _{θ(J-A)} : 27 °C/W				
	T _A : 71.6°C				
Condition		Vin : 220Vac, 60Hz		Load : 100%	T _{amb.} : 50°C
Components					
BD1 (Bridge Diode)	T _{j(max)} : 150 °C	P _d : 0.05 W	T _j = 72.7 °C	Derating Ratio = 48.5%	
	R _{θ(J-A)} : 134 °C/W				
	T _A : 66.0°C				
IC1 (IC + FET)	T _{j(max)} : 150 °C	P _d : 0.04 W	T _j = 84.3 °C	Derating Ratio = 56.2%	
	R _{θ(J-A)} : 100 °C/W				
	T _A : 80.3°C				
D4 (Rectifier Diode)	T _{j(max)} : 175 °C	P _d : 0.18 W	T _j = 77.9 °C	Derating Ratio = 44.5%	
	R _{θ(J-A)} : 27 °C/W				
	T _A : 73.0°C				

6. Abnormal Test

Page 41 of 47

Report No. 077-2166013-000

IEC 60950-1/Am1						
Clause	Requirement + Test	Result - Remark				Verdict
*Core considered as Primary						
5.3	TABLE: Fault condition tests					P
	Ambient temperature (°C)	20 - 25				—
	Power source for EUT: Manufacturer, model/type, output rating	-				—
Component No.	Fault	Supply voltage (V)	Test time	Fuse #	Fuse current (A)	Observation
1. D21	SC	264 Vac	10 min	N/A	N/A	Immediately output IP, NC, NT, NCD, NH, NB. FI: 0 to 0.01 A
2. C21	SC	264 Vac	10 min	N/A	N/A	Immediately output IP, NC, NT, NCD, NH, NB. FI: 0 to 0.01 A
3. PC1 (1, 2)	SC	264 Vac	10 min	N/A	N/A	Immediately output IP, NC, NT, NCD, NH, NB. FI: 0 to 0.01 A
4. PC1 (3, 4)	SC	264 Vac	10 min	N/A	N/A	Immediately output IP, NC, NT, NCD, NH, NB. FI: 0 to 0.02 A
5. IC1 (1, 2)	SC	264 Vac	10 min	N/A	N/A	Immediately output IP, NC, NT, NCD, NH, NB. FI: 0 to 0.02 A
6. *IC1 (1, 7)	SC	264 Vac	1 sec	N/A	N/A	Immediately fusible resistor(FR1) opened, NC, NT, NB, NH. FI: 0 A
7. *C2	SC	264 Vac	1 sec	N/A	N/A	Immediately fusible resistor(FR1) opened, L2 damaged, NC, NT, NB, NH. FI: 0 A
8. *BD1 (+, ~)	SC	264 Vac	1 sec	N/A	N/A	Immediately fusible resistor(FR1) opened, L2 damaged, NC, NT, NB, NH. FI: 0 A
Overload test						
TS5-05 Output, T1	Overload	264 Vac	2hr 22min	N/A	N/A	Load: 1.7A -Temperature Stabilized, <Measured temperature, °C> T1 Coil: 80.4, T1 Core: 72.2 Ambient: 21.9 Load: 1.8A -Unit IP, NC, NT, NB, NH FI: 0.11A
TS5-12 Output, T1	Overload	264 Vac	2hr 58min	N/A	N/A	Load: 0.8A -Temperature Stabilized, <Measured temperature, °C> T1 Coil: 79.2, T1 Core: 74.2 Ambient: 20.0 Load: 0.85A -Unit IP, NC, NT, NB, NH FI: 0.11A

TRF No. IEC60950_1C

IEC 60950-1/Am1						
Clause	Requirement + Test				Result - Remark	Verdict
TS5-15 Output, T1	Overload	264 Vac	1hr 54min	N/A	N/A	Load: 0.6A -Temperature Stabilized, <Measured temperature, °C> T1 Coil: 69.6, T1 Core: 71.3 Ambient: 21.1 Load:0.63A -Unit IP, NC, NT, NB, NH FI: 0.11A
TS5-24 Output, T1	Overload	264 Vac	2hr 6min	N/A	N/A	Load: 0.48A -Temperature Stabilized, <Measured temperature, °C> T1 Coil: 70.2, T1 Core: 63.5 Ambient: 22.2 Load: 0.49A -Unit IP, NC, NT, NB, NH FI: 0.11A
supplementary information:						
IP – Internal Protection occurred, NT - Tissue paper remained intact NC - Cheesecloth remained intact, NB - No indication of dielectric breakdown, NCD – No component damaged, FI – Final Input Current *** 10 times repeat test						

TRF No. IEC60950_1C

– Application Sheet

1. Basic Connection

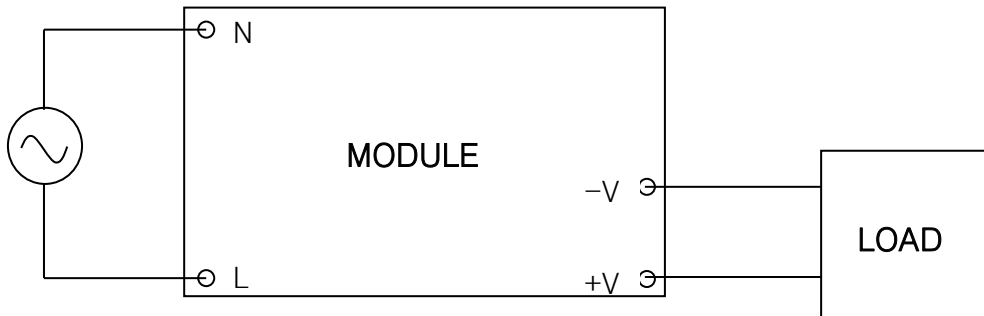

AC INPUT : 90Vac ~ 264Vac (Free Voltage)

※ To avoid excessive voltage drop and improved noise, short and thick wire should be used to connect the load.

2. EMI(Electro Magnetic Interference) Connection

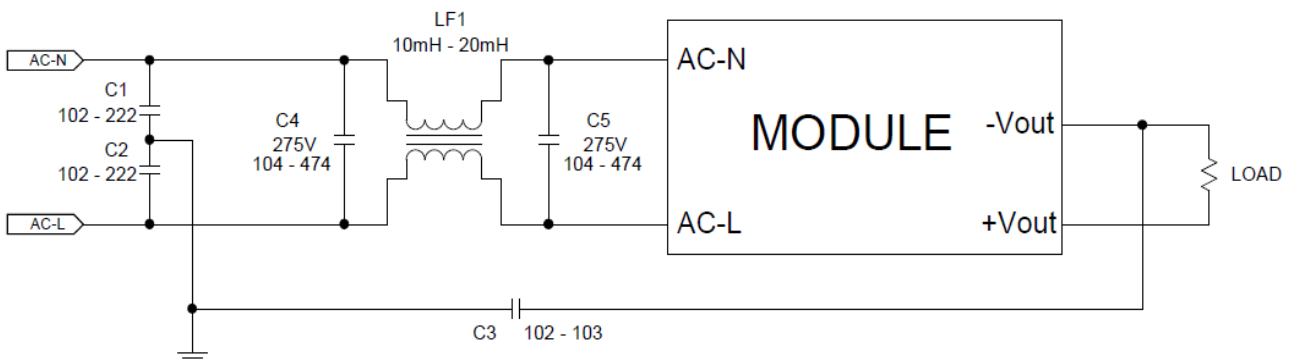

C1, C2	Y-Cap. AC 250V ~ 400V / 1000pF ~ 2200pF
C3	Y-Cap. AC 250V ~ 400V / 1000pF ~ 10000pF
C4, C5	X-Cap. AC 275V / 100nF ~ 470nF
LF1	Common mode line filter 10mH ~ 20mH

3. Output Section

Output Ripple and Noise Measurement Method

The measurement for output ripple and noise are based on normal probe with 20MHz bandwidth scope. Upon measurement of the ripple voltage, make sure that the scope probe leads are not too long. If a precise measurement can be made, the noise occurs from circumference must be reduced.

Regulation

Line Regulation

The line regulation means to the change in output voltage when the input voltage is varied within the input voltage range, at constant load and constant ambient temperature. The measurement point for the output voltage are $\pm V_{out}$ pins respectively.

Load Regulation

The load regulation means to the change in output voltage when the load is changed from minimum load to maximum load, at constant input voltage and constant ambient temperature. The measurement point for the output voltage are $\pm V_{out}$ pins respectively.

4. Protection

Over Current Protection

The TS series is built into an OCP(Over Current Protection) circuit. When the OCP triggers, the output voltage will fall. If overload condition is removed, the output will automatically recover.

Short Circuit Protection

The TS series is built into an short circuit protection circuit. It is similar to OCP circuit. When output is short condition, the output voltage will fall. If short condition is removed, the output will automatically recover. However, if the short condition continues damage to the module could occur.

5. Operation Method

Parallel Operation

The module can be operated parallel connection. Refer to diagram as shown below.

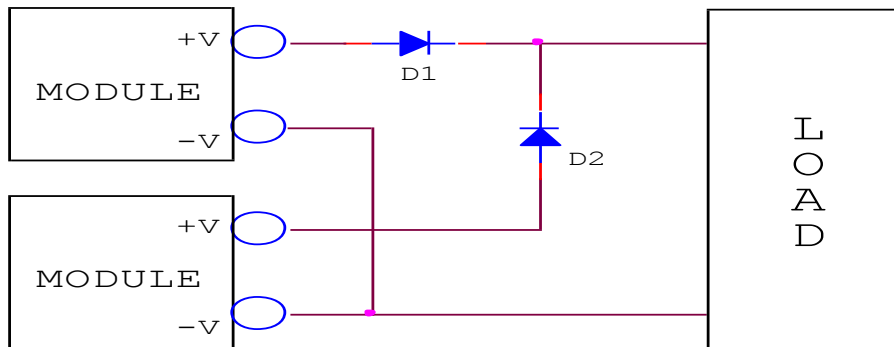

Please, you must consider both reverse voltage and forward current of diode, when you choose a diode.

Maximum reverse voltage(V_{rm}) : $V_{rm} > 1.5 \times V_o$

Forward current(I_f) : $I_f > 3 \times I_o$

Also, design a heatsink according to power loss at diode. If you want to reduce power loss, use a schottky barrier diode.

Power loss = $V_f(\text{forward voltage}) \times I_o(\text{output current})$

Series Operation

Series operation is available by connecting the outputs of two or more module as shown below.

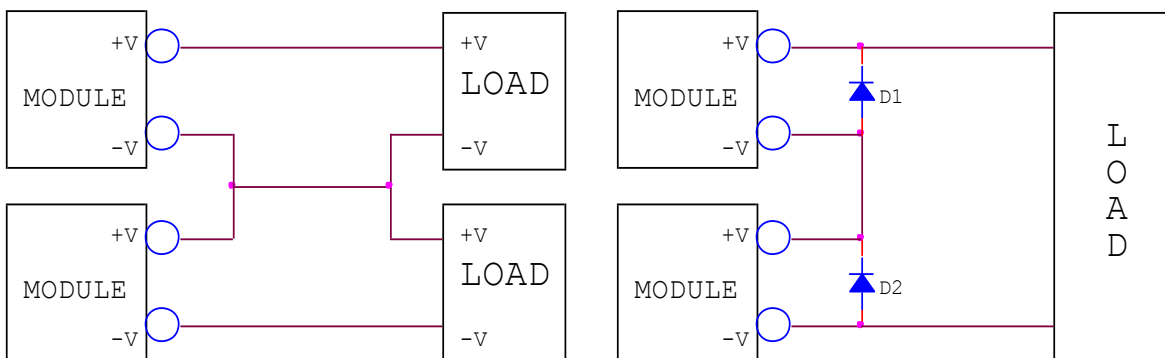

< A. General Series Operation >

< B. Complemental Series Operation >

Please, you must consider both reverse voltage and forward current of diode, when you choose a diode.

Maximum reverse voltage(V_{rm}) : $V_{rm} > 1.5 \times V_o$

Forward current(I_f) : $I_f > 3 \times I_o$

Also, design a heatsink according to power loss at diode. If you want to reduce power loss, use a schottky barrier diode.

Power loss = $V_f(\text{forward voltage}) \times I_o(\text{output current})$

6. Environment

Temperature

Operation Temperature

The range of ambient temperature in °C over which a module can be operated safely at either rated or derated output power. Refer to derating curve as shown below.

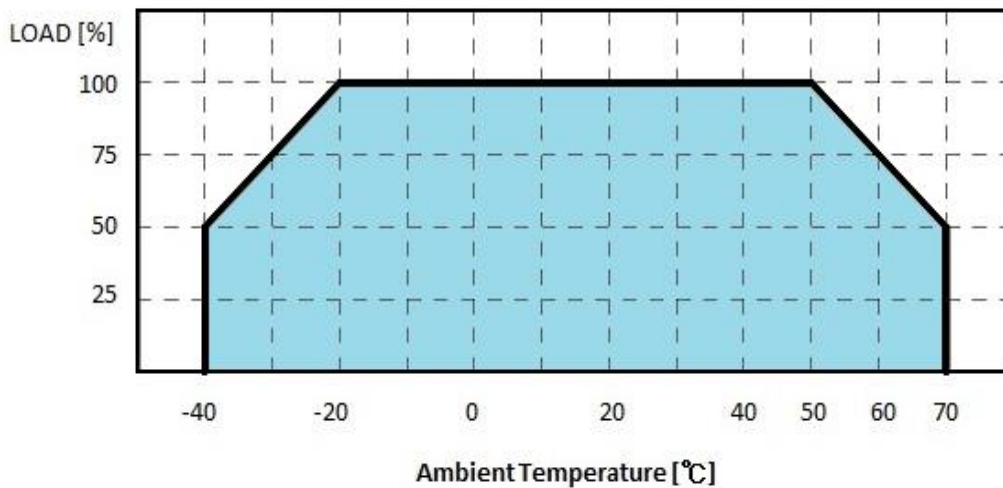

※ Operating Temperature Range : From -40°C to 70°C

< Derating Curve >

Storage Temperature

The range of ambient temperature in °C over which a module may be stored long term without damage. The storage temperature range is from -40°C to 85°C.

Humidity

Operation Humidity

The range of ambient humidity in % over which a module can be operated safely at either rated or derated output power. Refer to derating curve as shown below. The operating humidity range is from 20% to 90%RH.

Storage Humidity

The range of ambient humidity in % over which a module may be stored long term without damage. The storage humidity range is from 20% to 90%RH.

7. Isolation

Isolation Resistance

The electrical separation between input and output of a module by means of the power transformer. The isolation resistance is a function of materials and spacings employed throughout the module. Please don't test with a voltage above standard voltage for the Isolation Resistance Test.

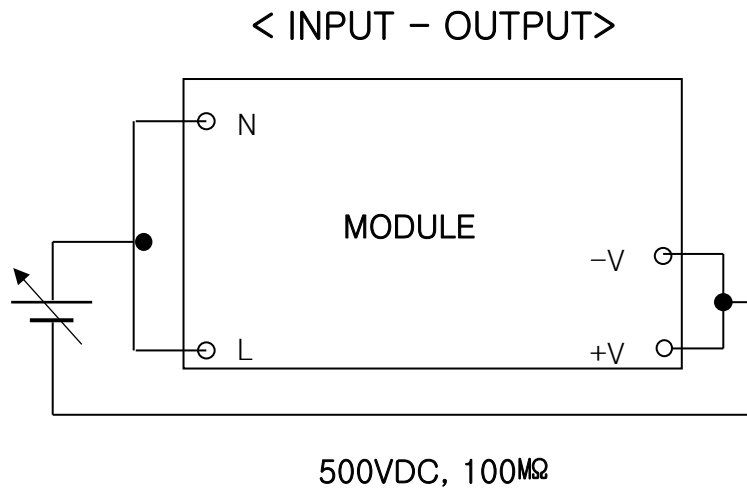

Withstand Voltage

For the withstand voltage test, the applied voltage must be increased gradually from zero to the testing value, and then decreased gradually at shut down. Especially stay away from use of a timer. Where a pulse of several times the applied voltage can be generated.

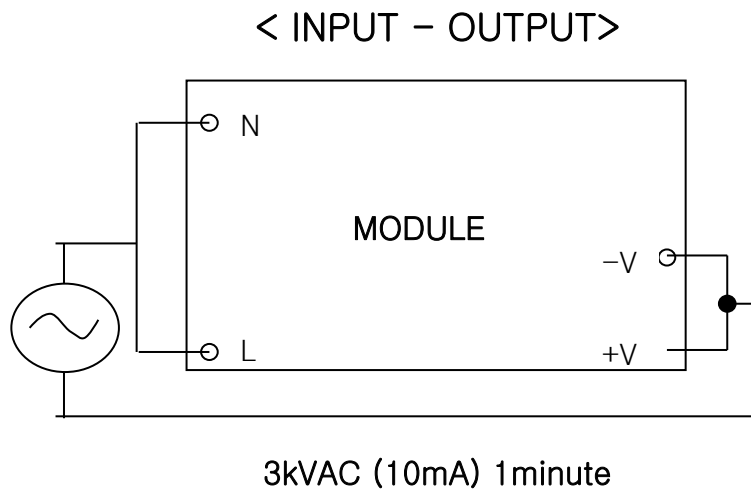

8. Outline Dimensions <Unit : mm (inch)>

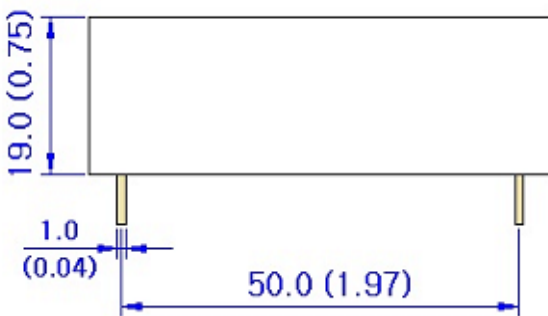

NOTE

1. Unit : mm (inch)
2. Weight : 50g(Max.)
3. Material : PBT

Mounting Hole <Top View>

