

LCD Module Specification

Model No.: LG12864B-FFDWH6V-NT

Table of Contents

1. BASIC SPECIFICATIONS	2
2. ABSOLUTE MAXIMUM RATINGS	3
3. ELECTRICAL CHARACTERISTICS	4
4. OPERATING PRINCIPLES & METHODS	7
5. DISPLAY CONTROL INSTRUCTIONS	10
6. DISPLAY DATA RAM ADDRESS MAP	13
7. CONNECTION WITH 8051 FAMILY MPU	14
8. ELECTRO-OPTICAL CHARACTERISTICS	15
9. DIMENSIONAL OUTLINE	16
10. LCD MODULE NUMBERING SYSTEM	17
11. PRECAUTIONS FOR USE OF LCD MODULE	18

RECORD OF REVISION

Rev.	Date	Page	Item	Description
0.1	2010/03/12	-	-	New release
0.2	2014/02/18	6	3.3, 3.4	Modify LED backlight characteristics and power supply circuit
0.3	2016/01/26	All pages	-	Adjust content organization.

1. BASIC SPECIFICATIONS

1.1 Features

Item	Specifications	Unit
Display Format	128 x 64 + 4 Icons	dot
LCD Type	FSTN - Positive - Transflective Black characters on white background	-
Driving Method	1/64 Duty, 1/9 Bias	-
Viewing Direction	6	O'clock
Backlight & Color	LED, white color	-
Outline Dimension (WxHxT)	54.0 x 50.0 x 8.7	mm
Viewing Area (WxH)	43.5 x 29.0	mm
Active Area (WxH)	40.92 x 24.92	mm
Dot Pitch (WxH)	0.32 x 0.32	mm
Dot Size (WxH)	0.28 x 0.28	mm
Weight	25	g
Controller	NT7108C	-
Interface	8-bit parallel (6800 series MPU)	-
Power Supply (VDD)	5.0 (built-in voltage converter for LCD driving)	V

1.2 Block Diagram

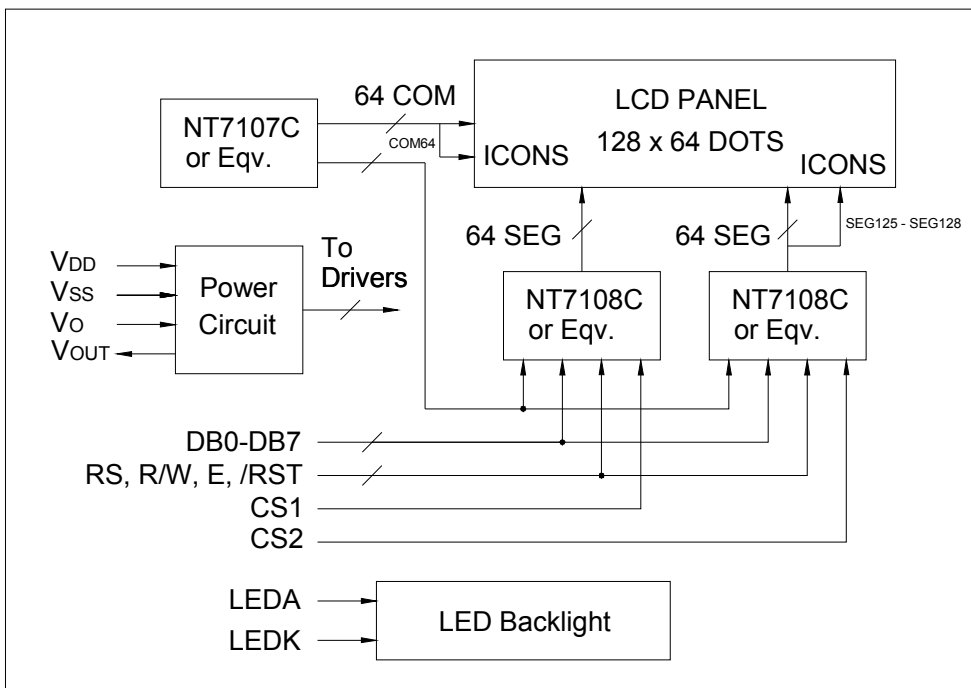

1.3 Terminal Functions

Pin No.	Symbol	Level	Function
1	VSS	0V	Ground
2	VDD	5V	Power supply for logic
3	VO	-	Operating voltage for LCD (contrast adjusting) Refer to section 3.5
4	RS	H/L	Data or instruction selection H: Display data L: Instruction code
5	R/W	H/L	Read or write selection H: Read operation L: Write operation
6	E	H, H→L	Enable signal. In read mode (R/W="H"), data appears at DB0 to DB7 while E is "H". In write mode (R/W="L"), data of DB0 to DB7 is latched at the falling edge of E.
7	DB0	H/L	Data bus
8	DB1	H/L	
9	DB2	H/L	
10	DB3	H/L	
11	DB4	H/L	
12	DB5	H/L	
13	DB6	H/L	
14	DB7	H/L	
15	CS1	H	Chip selection for IC1 (left half panel). Active "H".
16	CS2	H	Chip selection for IC2 (right half panel). Active "H".
17	/RST	L	Reset signal. Active "L".
18	VOUT	-10V	Output voltage of the on-board DC-DC converter.
19	LEDA	5V	Power supply for LED backlight Refer to section 3.3 to 3.4
20	LEDK	0V	

2. ABSOLUTE MAXIMUM RATINGS

Item	Symbol	Min.	Max.	Unit
Supply Voltage (Logic)	VDD-VSS	-0.3	6.0	V
Supply Voltage (LCD)	VDD-VO	-0.3	19.0	V
Input Voltage	VI	-0.3	VDD+0.3	V
Operating Temperature	Topr	-20	70	°C
Storage Temperature	Tstg	-30	80	°C

Cautions: Stresses above those listed as 'absolute maximum ratings' may cause permanent damage to the device. This is a stress rating only and functional operation of the device under these conditions is not implied. Exposure to maximum rating conditions for extended periods may affect device reliability.

3. ELECTRICAL CHARACTERISTICS

3.1 DC Characteristics (Ta=25°C)

Item	Symbol	Condition	Min.	Typ.	Max.	Unit
Supply Voltage (Logic)	VDD		4.5	5.0	5.5	V
Supply Voltage (LCD Drive)	VDD-VO		-	11.2	-	V
Input High Voltage	VIH		2.0	-	VDD	V
Input Low Voltage	VIL		0	-	0.8	V
Output High Voltage	VOH	IOH=-0.2mA	2.4	-	VDD	V
Output Low Voltage	VOL	IOL=1.6mA	0	-	0.4	V
Supply Current (Logic)	IDD	VDD=5.0V	-	6.0	8.0	mA

3.2 Interface Timing Chart (VDD=5.0V±10%, Ta=25°C)

Characteristic	Symbol	Min.	Typ.	Max.	Unit
E Cycle	t _C	1000	-	-	ns
E High Level Width	t _{WH}	450	-	-	ns
E Low Level Width	t _{WL}	450	-	-	ns
E Rise Time	t _R	-	-	25	ns
E Fall Time	t _F	-	-	25	ns
Address Set-Up Time	t _{ASU}	140	-	-	ns
Address Hold Time	t _{AH}	10	-	-	ns
Data Set-Up Time	t _{DSU}	140	-	-	ns
Data Delay Time	t _D	-	-	320	ns
Data Hold Time(Write)	t _{DHW}	10	-	-	ns
Data Hold Time(Read)	t _{DHR}	20	-	-	ns

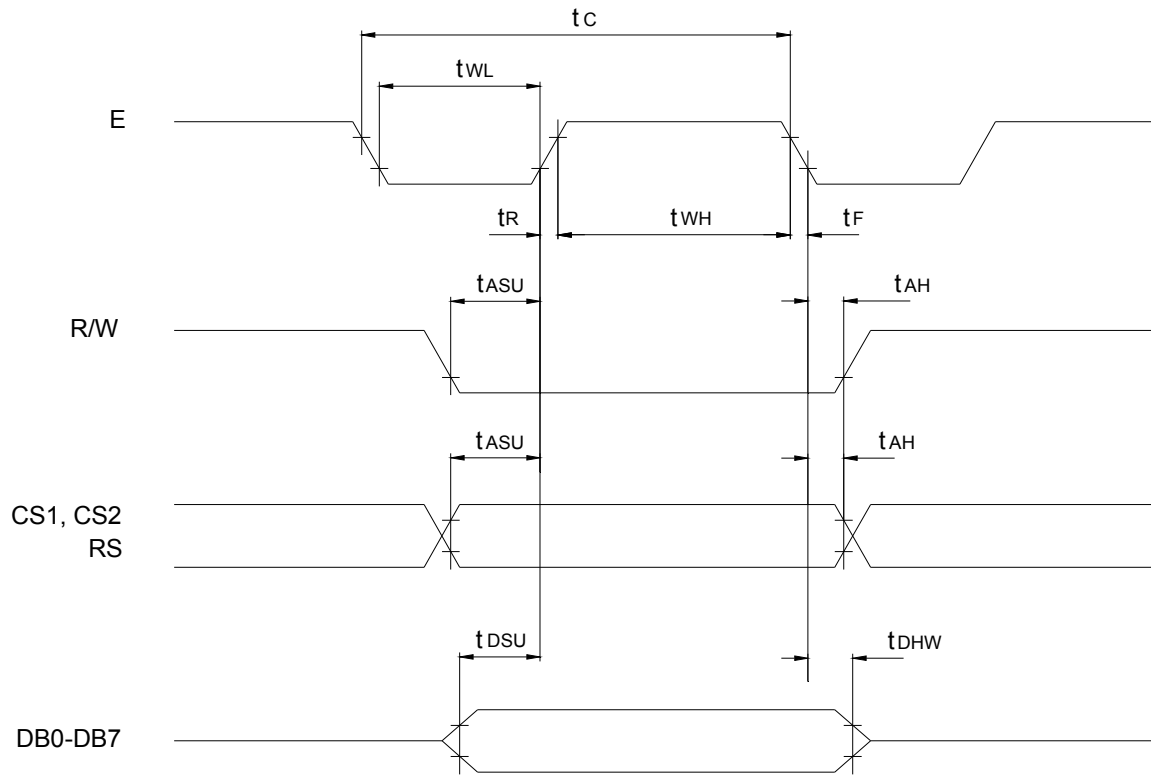

MPU Write Timing

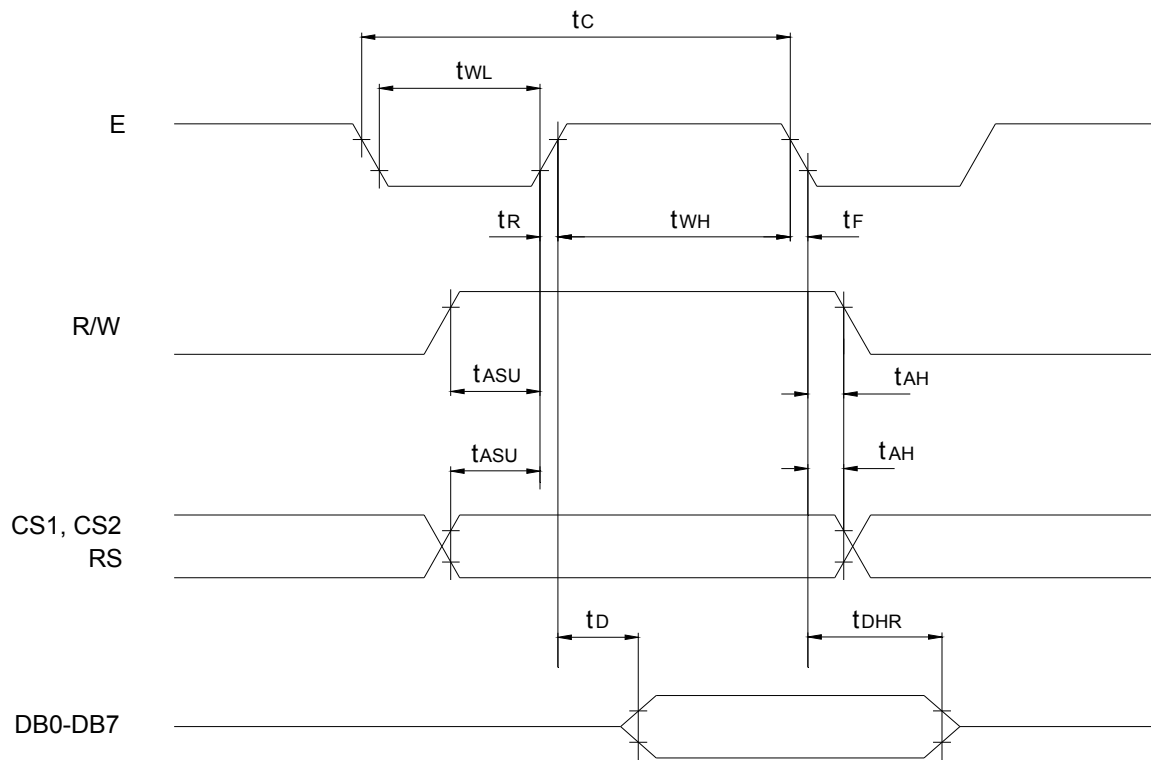

MPU Read Timing

3.3 LED Backlight Characteristics (Ta=25°C)

Item	Symbol	Condition	Min.	Typ.	Max.	Unit
Forward Voltage	Vf		2.7	2.8	2.9	V
Forward Current	If	Vf=2.8V	-	30	-	mA
Color	White					

3.4 Power Supply for LED Backlight

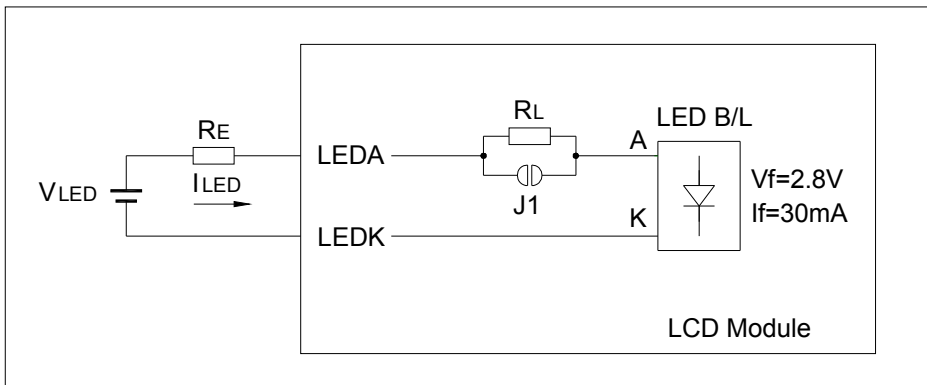

RL (internal) and RE (external) are the current limiting resistors for LED backlight

VLED	Jumper Status	RE Values	Remark
5V	J1 open	0Ω	Default
Higher than 5V	J1 open	$(V_{LED} - 5.0V)/30mA$	
Lower than 5V	J1 close	$(V_{LED} - 2.8V)/30mA$	

3.5 Power Supply for Logic and LCD Driving

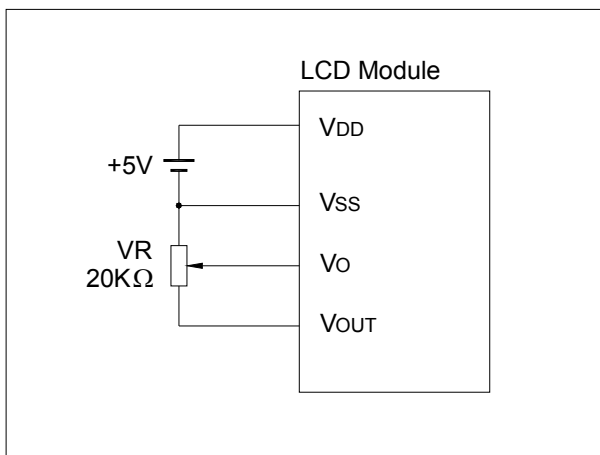

Vo is LCD driving voltage (contrast adjusting). Adjust VDD-Vo to be around 11.2V for better contrast.

4. OPERATING PRINCIPLES & METHODS

4.1 I/O Buffer

Input buffer controls the status between the enable and display of chip. Unless the IC (selected by CS1 or CS2) is in active mode, input or output of data and instruction does not execute. Therefore internal state is maintained. But /RST can operate regardless the level of CS1 or CS2.

4.2 Register

Both input register and output register are provided to interface to MPU of which the speed is different from that of internal operation. The selections of these registers depend on the combination of R/W and RS signals.

RS	R/W	Function
L	L	Instruction
	H	Status read (busy check)
H	L	Data write (from input register to display data RAM)
	H	Data read (from display data RAM to output register)

4.2.1 Input Register

Input register stores the data temporarily before writing it into display data RAM. When the IC is in active mode, R/W and RS select the input register. The data from MPU is written into input register, then into display data RAM. Data is latched at falling edge of the E signal and then written into the display data RAM automatically by internal operation.

4.2.2 Output Register

Output register stores the data temporarily which is read from display data RAM when the IC is in active mode and R/W and RS=H, stored data in display data RAM is latched in output register. When the IC is in active mode and R/W=H, RS=L, status data (busy check) can be read out.

To read the contents of display data RAM, twice access of read instruction is needed. In first access, data in display data RAM is latched into output register. In second access, MPU can read data that is latched in output register. That is, to read the data in display data RAM, it needs dummy read. But status read does not need dummy read.

The following shows the MPU read timing.

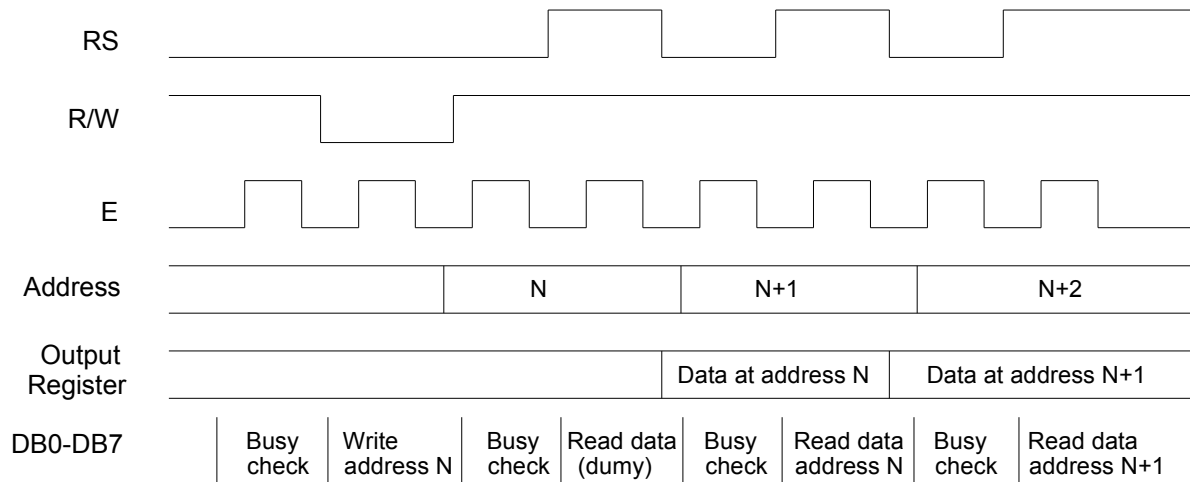

MPU Read Timing

4.3 Reset

The system can be initialized by setting /RST terminal at low level when turning power on. When /RST becomes low, following procedure is occurred.

1. Display off
2. Display start line register is set by 0. (Z address 0)

While /RST is low level, no instruction except status read can be accepted. Reset status appears at DB4 of status byte, after DB4 becomes “L”, any instruction can be accepted. The conditions of power supply at initial power up are shown below.

Item	Symbol	Min.	Typ.	Max.	Unit
Reset time	t_{RS}	1.0	-	-	μs
Rise time	t_R	-	-	200	ns

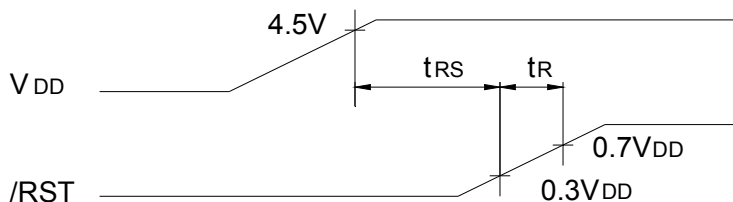

4.4 Busy Flag

Busy flag indicates the system is now internally operating or not. When busy flag is “H”, the system is in internal operation. When busy flag is “L”, the system can accept data or instruction. Busy flag is read out on DB7 by the Status Read instruction.

4.5 Display On/Off Flip-Flop

The display on/off flip-flop makes on/off the liquid crystal display. When flip-flop is reset (logical low), selective voltage or non selective voltage appears on segment output terminals. When flip-flop is set (logical high), non selective voltage appears on segment output terminals regardless of display RAM data.

The display on/off flip-flop can change status by instruction. The display data at all segments disappear while /RST is low. The status of the flip-flop is output on DB5 by Status Read instruction.

4.6 X Page Register

X page register designates page of the internal display data RAM. Count function is not available. The address is set by instruction.

4.7 Y Address Counter

Y address counter designates address of the internal display data RAM. The address is set by instruction and is increased by 1 automatically by read or write operations of display data.

4.8 Display Data RAM

Display data RAM stores a display data for liquid crystal display. 1 bit data of this RAM corresponds to light ON (data=1) or light OFF (data=0) of 1 dot on the display panel.

4.9 Display Start Line Register

The register specifies a line in display data RAM that corresponds to the top line of LCD panel, when displaying contents in display data RAM on the LCD panel. Bit data (DB<0:5>) of the display start line information is written into this register by display start line set instruction. It is used for scrolling of the liquid crystal display screen.

5. DISPLAY CONTROL INSTRUCTIONS

The display control instructions control the internal state of the NT7108C. Instruction is received from MPU to NT7108C for the display control. The following table shows various instructions.

Instruction	RS	R/W	DB7	DB6	DB5	DB4	DB3	DB2	DB1	DB0	Function	
Display ON/OFF	0	0	0	0	1	1	1	1	1	0/1	Control the display on or off. Internal status and display RAM data are not affected.	
Set Address (Y address)	0	0	0	1	Y address (0-63)						Set the Y address at the Y address counter.	
Set Page (X address)	0	0	1	0	1	1	1	Page (0-7)			Set the X address at the X address register.	
Display Start Line (Z address)	0	0	1	1	Display start line (0-63)						Indicate the display data RAM displayed at the top of the screen.	
Status Read	0	1	B U S Y	0	O N / O F F	R E S E T	0	0	0	0	Read status. BUSY 0: Ready 1: In internal operation ON/OFF 0: Display ON 1: Display OFF RESET 0: Normal 1: Reset	
Write Display Data	1	0	Display Data									Write data (DB0-DB7) into display data RAM. After writing instruction, Y address is increased by 1 automatically.
Read Display Data	1	1	Display Data									Read data (DB0-DB7) from display data RAM to the data bus.

5.1 Display On/Off

RS	R/W	DB7	DB6	DB5	DB4	DB3	DB2	DB1	DB0
0	0	0	0	1	1	1	1	1	D

The display data appears when D is 1 and disappears when D is 0.

Though the data is not on the screen with D=0, it remains in the display data RAM.

Therefore, you can make it appear by changing D=0 into D=1.

5.2 Set Address (Y Address)

RS	R/W	DB7	DB6	DB5	DB4	DB3	DB2	DB1	DB0
0	0	0	1	AC5	AC4	AC3	AC2	AC1	AC0

Y address (AC0-AC5) of the display data RAM is set in the Y address counter.

The address is set by instruction and increased by 1 automatically by read or write operations of display data.

5.3 Set Page (X Address)

RS	R/W	DB7	DB6	DB5	DB4	DB3	DB2	DB1	DB0
0	0	1	0	1	1	1	AC2	AC1	AC0

X address (AC0-AC2) of the display data RAM is set in the X address register.

Writing or reading to or from MPU is executed in this specified page until the next page is set.

5.4 Display Start Line (Z Address)

RS	R/W	DB7	DB6	DB5	DB4	DB3	DB2	DB1	DB0
0	0	1	1	AC5	AC4	AC3	AC2	AC1	AC0

Z address (AC0-AC5) of the display data RAM is set in the display start line register and displayed at the top of the screen.

5.5 Status Read

RS	R/W	DB7	DB6	DB5	DB4	DB3	DB2	DB1	DB0
0	1	BUSY	0	ON/OFF	RESET	0	0	0	0

- BUSY**
 When BUSY is 1, the chip is executing internal operation and no instructions are accepted.
 When BUSY is 0, the chip is ready to accept any instructions.
- ON/OFF**
 When ON/OFF is 1, the display is off.
 When ON/OFF is 0, the display is on.
- RESET**
 When RESET is 1, the system is being initialized.
 In this condition, no instructions except status read can be accepted.
 When RESET is 0, initializing has finished and the system is in the normal operation condition.

5.6 Write Display Data

RS	R/W	DB7	DB6	DB5	DB4	DB3	DB2	DB1	DB0
1	0	D7	D6	D5	D4	D3	D2	D1	D0

Write data (D0-D7) into the display data RAM.

After writing instruction, Y address is increased by 1 automatically.

5.7 Read Display Data

RS	R/W	DB7	DB6	DB5	DB4	DB3	DB2	DB1	DB0
1	1	D7	D6	D5	D4	D3	D2	D1	D0

Read data (D0-D7) from the display data RAM.

After reading instruction, Y address is increased by 1 automatically.

One time of dummy read must be required after column address setting.

6. DISPLAY DATA RAM ADDRESS MAP

Page (X) Address	Display Data	1st NT7108C (IC1) (CS1=H, CS2=L)							2nd NT7108C (IC2) (CS1=L, CS2=H)							Line (Z) Address	Common
0	D0														0	COM1	
	D1														1	COM2	
	D2														2	COM3	
	D3														3	COM4	
	D4														4	COM5	
	D5														5	COM6	
	D6														6	COM7	
	D7														7	COM8	
1	D0														8	COM9	
	D1														9	COM10	
	D2														10	COM11	
	D3														11	COM12	
	D4														12	COM13	
	D5														13	COM14	
	D6														14	COM15	
	D7														15	COM16	
2	D0														16	COM17	
	D1														17	COM18	
	D2														18	COM19	
	D3														19	COM20	
	D4														20	COM21	
	D5														21	COM22	
	D6														22	COM23	
	D7														23	COM24	
3	D0														24	COM25	
	D1														25	COM26	
	D2														26	COM27	
	D3														27	COM28	
	D4														28	COM29	
	D5														29	COM30	
	D6														30	COM31	
	D7														31	COM32	
4	D0														32	COM33	
	D1														33	COM34	
	D2														34	COM35	
	D3														35	COM36	
	D4														36	COM37	
	D5														37	COM38	
	D6														38	COM39	
	D7														39	COM40	
5	D0														40	COM41	
	D1														41	COM42	
	D2														42	COM43	
	D3														43	COM44	
	D4														44	COM45	
	D5														45	COM46	
	D6														46	COM47	
	D7														47	COM48	
6	D0														48	COM49	
	D1														49	COM50	
	D2														50	COM51	
	D3														51	COM52	
	D4														52	COM53	
	D5														53	COM54	
	D6														54	COM55	
	D7														55	COM56	
7	D0														56	COM57	
	D1														57	COM58	
	D2														58	COM59	
	D3														59	COM60	
	D4														60	COM61	
	D5														61	COM62	
	D6														62	COM63	
	D7														63	COM64	
	Column (Y) Address	0	1	2	-	61	62	63	0	1	2	-	61	62	63		
	Segment	SEG1	SEG2	SEG3	-	SEG62	SEG63	SEG64	SEG65	SEG66	SEG67	-	SEG126	SEG127	SEG128		

LCD PANEL
128 X 64 DOTS

7. CONNECTION WITH 8051 FAMILY MPU

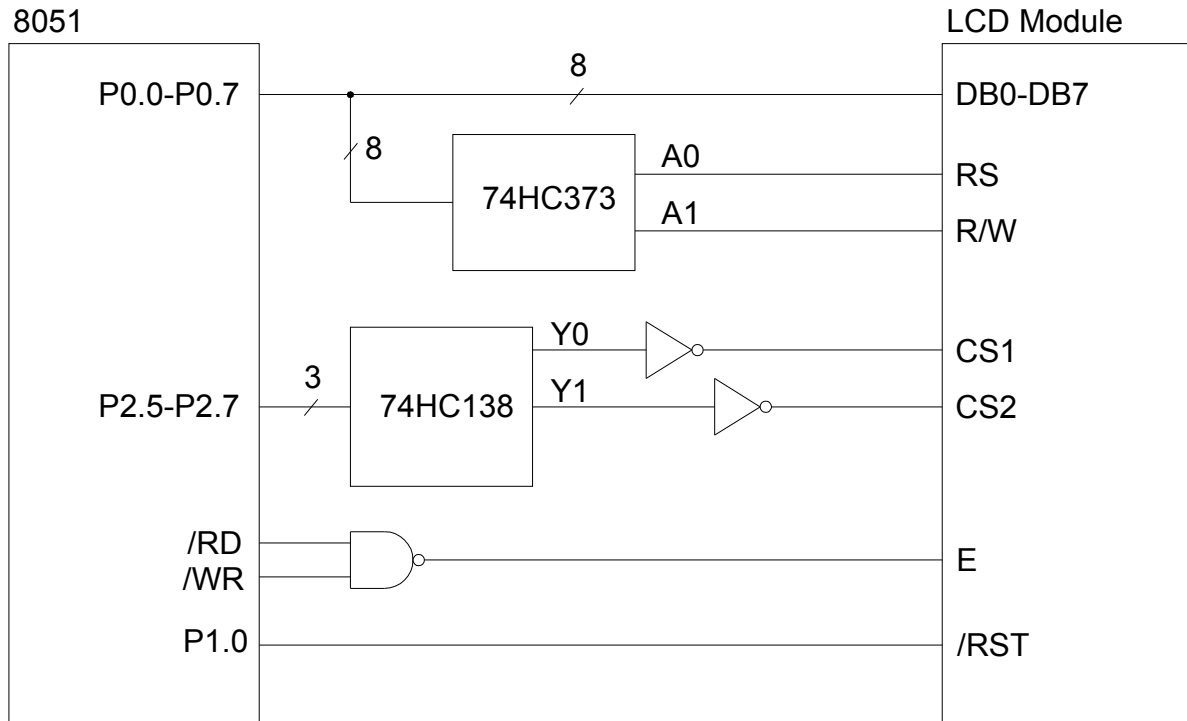

a. Application Circuit 1

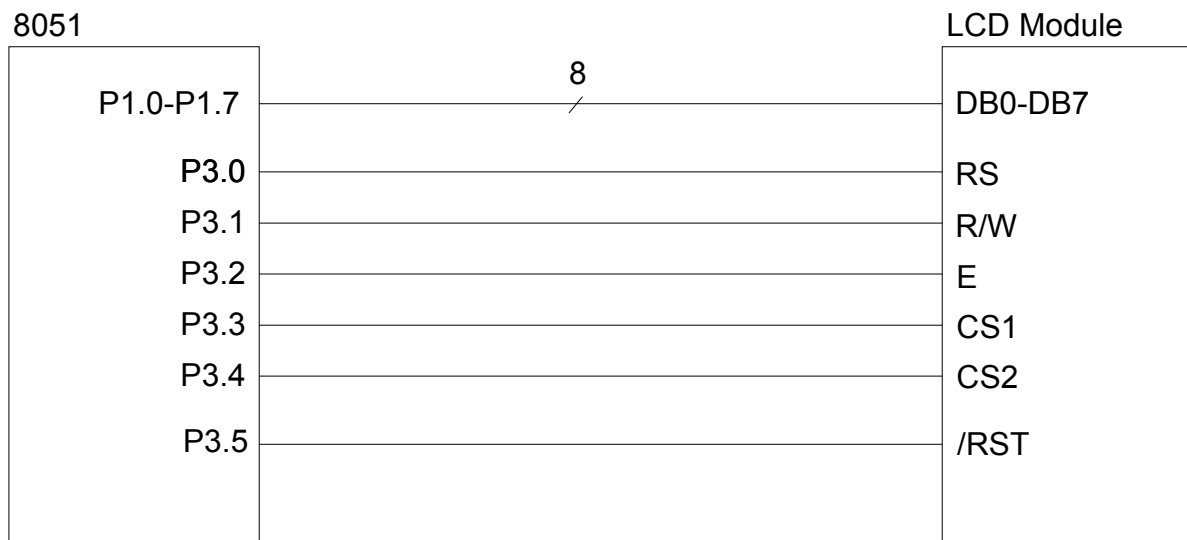

b. Application Circuit 2

8. ELECTRO-OPTICAL CHARACTERISTICS (Ta=25°C)

Item	Symbol	Condition	Min.	Typ.	Max.	Unit	Note
View Angle	$\Phi 2-\Phi 1$	$Cr \geq 2, \theta = 0^\circ$	-	70	-	Deg	Note1, Note2
Contrast Ratio	Cr	$\Phi = 0^\circ, \theta = 0^\circ$	3	-	-	-	Note3
Response Time	tr (rise)	$\Phi = 0^\circ, \theta = 0^\circ$	-	200	-	ms	Note4
	tf (fall)	$\Phi = 0^\circ, \theta = 0^\circ$	-	250	-	ms	

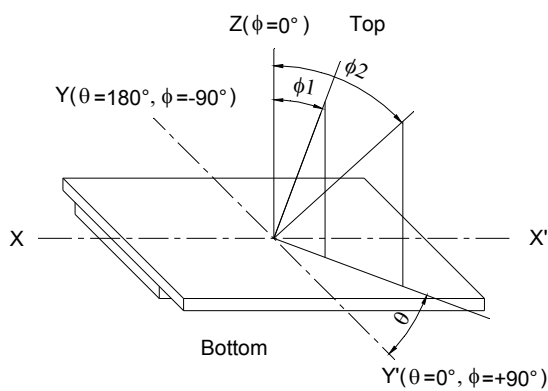

Note1: Definition of viewing angle ϕ, θ

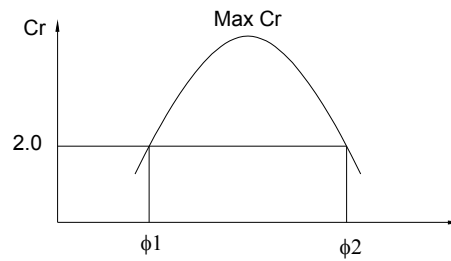

Note2: Definition of viewing angle range $\phi 1, \phi 2$

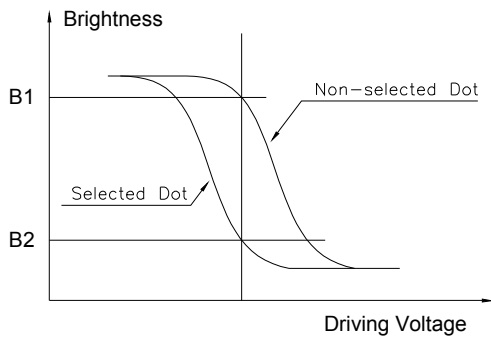

$$\text{Contrast Ratio} = \frac{\text{Brightness of non-selected dot (B1)}}{\text{Brightness of selected dot (B2)}}$$

Note3: Definition of contrast ratio (positive type)

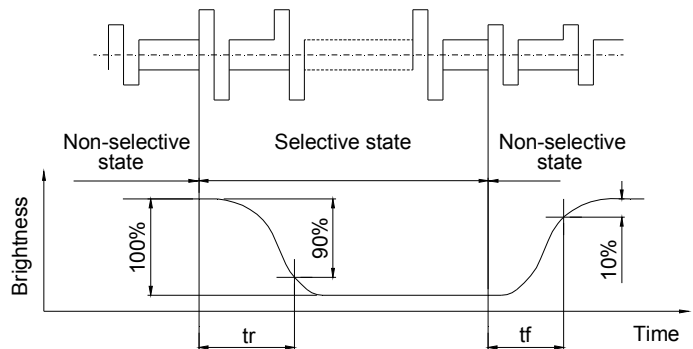

Note3: Definition of response time

9. DIMENSIONAL OUTLINE

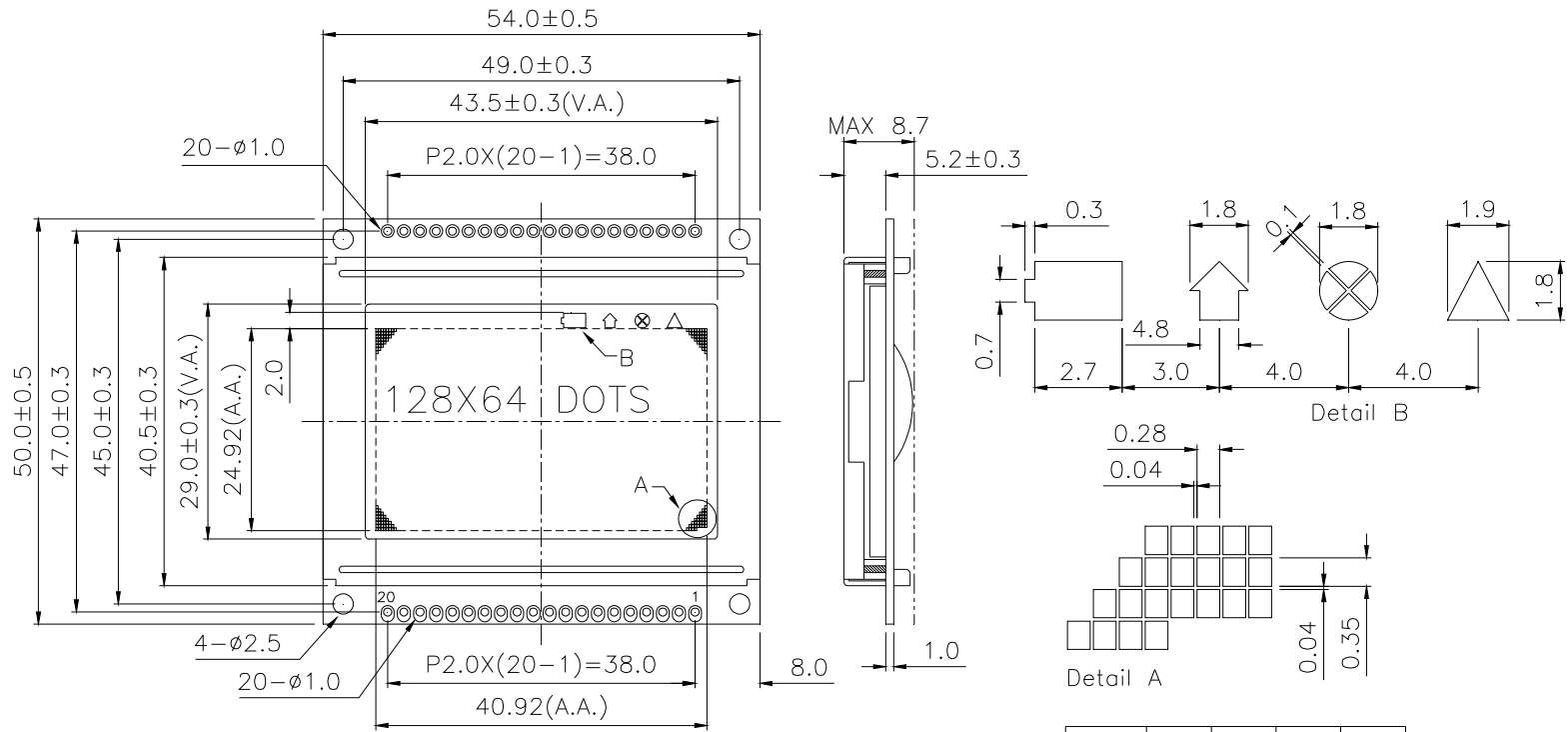

SEG	S125	S126	S127	S128
COM64				

PIN NO.	1	2	3	4	5	6	7	8	9	10	11	12	13	14	15	16	17	18	19	20
SYMBOL	V _{SS}	V _{DD}	V _O	RS	R/W	E	DB0	DB1	DB2	DB3	DB4	DB5	DB6	DB7	CS1	CS2	/RST	V _{OUT}	LEDA	LEDK

DWN.	LY	TITLE	LCM OUTLINE DIMENSION		
CHK.	LYJ	PART NO.	LG12864B-D		
APPD.		DWG. NO.	LG12864B-D-WXC		
REV.	C	UNIT	mm	PROJECTION	
DATE	2009.06.17	SCALE	NTS	SHEET	1 OF 1

10. LCD MODULE NUMBERING SYSTEM

L G 128 64 B - F F D W H 6 V - NT
 (1) (2) (3) (4) (5) (6) (7) (8) (9) (10) (11) (12) (13)

(1) Brand

(2) Module type

C - Character module

G - Graphic module

(3) Display format

Character module : Number of characters per line, two digits XX

Graphic module : Number of columns, three digits XXX

(4) Display format

Character module : Number of lines, one digit X

Graphic module : Number of rows, two or three digits XX or XXX

(5) Development number : One or two digits X or XX

(6) LCD mode

T - TN Positive, Gray

N - TN Negative, Blue

S - STN Positive, Yellow green

G - STN Positive, Gray

B - STN Negative, Blue

F - FSTN Positive, White

K - FSTN Negative, Black

L - FSTN Negative, Blue

Q - FFSTN Negative, Black

(7) Polarizer mode

R - Reflective

F - Transflective

M - Transmissive

(8) Backlight type

N - Without backlight

L - Array LED

D - Edge-lit LED

E - EL

C - CCFL

(9) Backlight color

Y - Yellow green

B - Blue

W - White

G - Green

A - Amber

R - Red

M - Multi color

Nil - Without backlight

(10) Operating temperature range

S - Standard temperature (0 to +50 °C)

H - Extended temperature (-20 to +70 °C)

(11) Viewing direction

3 - 3:00

6 - 6:00

9 - 9:00

U - 12:00

(12) DC-DC Converter

N or Nil - Without DC-DC converter

V - Built in DC-DC converter

(13) Version code

NT - NT7108C controller

11. PRECAUTIONS FOR USE OF LCD MODULE

11.1 Handling Precautions

- 1) The display panel is made of glass. Do not subject it to a mechanical shock by dropping it from a high place, etc.
- 2) If the display panel is damaged and the liquid crystal substance inside it leaks out, be sure not to get any in your mouth. If the substance comes into contact with your skin or clothes, promptly wash it off using soap and water.
- 3) Do not apply excessive force on the surface of display or the adjoining areas of LCD module since this may cause the color tone to vary.
- 4) The polarizer covering the display surface of the LCD module is soft and easily scratched. Handle this polarizer carefully.
- 5) If the display surface of LCD module becomes contaminated, blow on the surface and gently wipe it with a soft dry cloth. If it is heavily contaminated, moisten cloth with one of the following solvents.
 - Isopropyl alcohol
 - Ethyl alcoholSolvents other than those mentioned above may damage the polarizer. Especially, do not use the following:
 - Water
 - Ketone
 - Aromatic Solvents
- 6) When mounting the LCD module make sure that it is free of twisting, warping, and distortion. Distortion has great influence upon display quality. Also keep the stiffness enough regarding the outer case.
- 7) Be sure to avoid any solvent such as flux for soldering never stick to Heat-Seal. Such solvent on Heat-Seal may cause connection problem of heat-Seal and TAB.
- 8) Do not forcibly pull or bend the TAB I/O terminals.
- 9) Do not attempt to disassemble or process the LCD module.
- 10) NC terminal should be open. Do not connect anything.
- 11) If the logic circuit power is off, do not apply the input signals.
- 12) To prevent destruction of the elements by static electricity, be careful to maintain an optimum work environment.
 - Be sure to ground the body when handling the LCD module.
 - Tools required for assembly, such as soldering irons, must be properly grounded.
 - To reduce the amount of static electricity generated, do not conduct assembly and other work under dry conditions.
 - The LCD module is coated with a film to protect the display surface. Exercise care when peeling off this protective film since static electricity may be generated.

11.2 Storage Precautions

- 1) When storing the LCD module, avoid exposure to direct sunlight or to the light of fluorescent lamps and high temperature/high humidity. Whenever possible, the LCD module should be stored in the same conditions in which they were shipped

from our company.

- 2) Exercise care to minimize corrosion of the electrodes. Corrosion of the electrodes is accelerated by water droplets or a current flow in a high humidity environment.

11.3 Design Precautions

- 1) The absolute maximum ratings represent the rated value beyond which LCD module can not exceed. When the LCD modules are used in excess of this rated value, their operating characteristics may be adversely affected.
- 2) To prevent the occurrence of erroneous operation caused by noise, attention must be paid to satisfy VIL, VIH specification values, including taking the precaution of using signal cables that are short.
- 3) The liquid crystal display exhibits temperature dependency characteristics. Since recognition of the display becomes difficult when the LCD is used outside its designated operating temperature range, be sure to use the LCD within this range. Also, keep in mind that the LCD driving voltage levels necessary for clear displays will vary according to temperature.
- 4) Sufficiently notice the mutual noise interference occurred by peripheral devices.
- 5) To cope with EMI, take measures basically on outputting side.
- 6) If DC is impressed on the liquid crystal display panel, display definition is rapidly deteriorated by the electrochemical reaction that occurs inside the liquid crystal display panel. To eliminate the opportunity of DC impressing, be sure to maintain the AC characteristics of the input signals sent to the LCD Module.

11.4 Others

- 1) Liquid crystals solidify under low temperatures (below the storage temperature range) leading to defective orientation or the generation of air bubbles (black or white).
Air bubbles may also be generated if the LCD module is subjected to a strong shock at a low temperature.
- 2) If the LCD modules have been operating for a long time showing the same display patterns, the display patterns may remain on the screen as ghost images and a slight contrast irregularity may also appear. A normal operating status can be regained by suspending use for some time. It should be noted that this phenomenon does not adversely affect performance reliability.
- 3) To minimize the performance degradation of the LCD modules resulting from destruction caused by static electricity, etc., exercise care to avoid touching the following sections when handling the module:
 - Terminal electrode sections.
 - Part of pattern wiring on TAB, etc.