

DIP TYPE

SCO-06

- CMOS Output
- 3.3 V, 5.0 V Operating Supply Voltage Range
- 8 pin DIP Package
- Custom Lead Length Options Available
- Wide Frequency
- All-metal Welded Package



ELECTRICAL SPECIFICATIONS

ITEM	Value	Remarks
Output Logic Type	CMOS	CMOS XO
Frequency Range	1.000 to 200.0 MHz	
Supply Voltage(V _{DD})	3.3 V _{DC} ± 10 %, 5.0 V _{DC} ± 10 %	
Operating Temperature Range	0 to +70 °C, -20 to +70 °C, -40 to +85 °C	
Storage Temperature Range	-55 to +125 °C	
Frequency Stability	±20 ppm, ±25 ppm, ±50 ppm, ±100 ppm Max.	Over operating temperature range
Input Current	17 mA(3.3 V), 25(5.0 V) Max. 25 mA(3.3 V), 40(5.0 V) Max. 35 mA(3.3 V), 60(5.0 V) Max. 45 mA(3.3 V), 70(5.0 V) Max. 65 mA(3.3 V), 80(5.0 V) Max.	1.000 to 20.000MHz 20.001 to 40.000MHz 40.001 to 80.000MHz 80.001 to 125.000MHz 125.000 to 200.000MHz
Output Voltage Logic High(V _{OH})	90 % of V _{DD} Min.	
Output Voltage Logic Low(V _{OL})	10 % of V _{DD} Max.	
Rise / Fall Time	10 ns Max.(1.000 to 20.000MHz) 6 ns Max.(20.001 to 70.000MHz) 4 ns Max.(70.0001 to 125.000MHz) 2 ns Max.(125.000 to 200.000MHz)	Measured over 10 % to 90 % of waveform
Duty Cycle	45 to 55 %, 40 to 60 %	Measured at 50 % of waveform
Start-up Time	10 ms Max.	
Output Load Condition(CMOS)	15 pF Max.	
Output Enable Function (V _{IH} and V _{IL})	70 % of V _{DD} min. to Enable Output 30 % of V _{DD} max. to Enable Output	High Impedance
RMS Phase Jitter	1 ps Max.	BW : 12 kHz to 20 MHz
Frequency Aging	±5 ppm Max.	25°C, First year

MECHANICAL DIMENSIONS (mm)

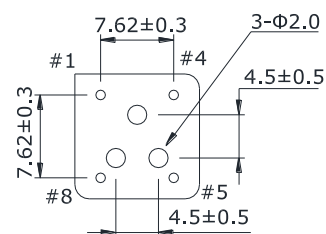
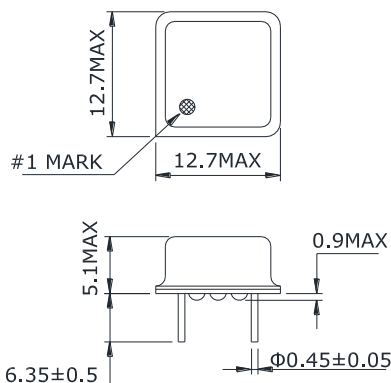

CONNECTION

- #1 : N.C or Tri-state
- #4 : GND
- #5 : OUTPUT
- #8 : V_{DD}

■ PART NUMBERING GUIDE

SCO – 06 33 50 B D S – 27.000M

SUPPLY VOLTAGE(V_{DD})
50 : 5.0 V, 33 : 3.3 V

FREQUENCY STABILITY
25 : ±25 ppm, 50 : ±50 ppm
BLANK : ±100 ppm

OPERATING TEMPERATURE RANGE
A : -40 to 85 °C, B : -20 to 70 °C
BLANK : 0 to 70 °C

FREQUENCY
M : MHz

PIN 1 CONNECTION
S : TRI-STATE, E/D
BLANK : NO CONNECTION

DUTY CYCLE
D : 45/55, E : 40/60

■ TEST CIRCUIT (CMOS)

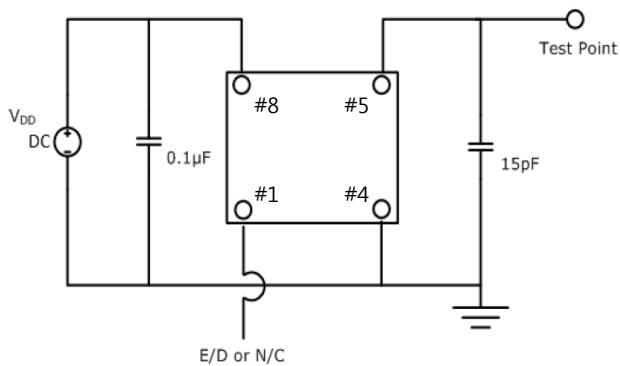

■ WAVEFORM (CMOS)

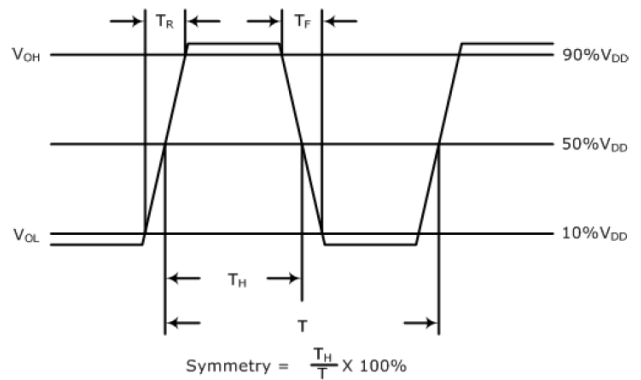

■ ENVIRONMENTAL & MECHANICAL SPECIFICATIONS

Temperature Cycling	MIL-STD-883, Method 1010, Condition B
Fine Leak Test	MIL-STD-883, Method 1014, Condition A
Gross Leak Test	MIL-STD-883, Method 1014, Condition C
Mechanical Shock	MIL-STD-202, Method 213, Condition C
Vibration	MIL-STD-883, Method 2007, Condition A
Moisture Resistance	MIL-STD-883, Method 1004
Moisture Sensitivity	J-STD-020, MSL 1
Resistance to Soldering Heat	MIL-STD-202, Method 210, Condition K
Solderability	MIL-STD-883, Method 2003

REFLOW PROFILE

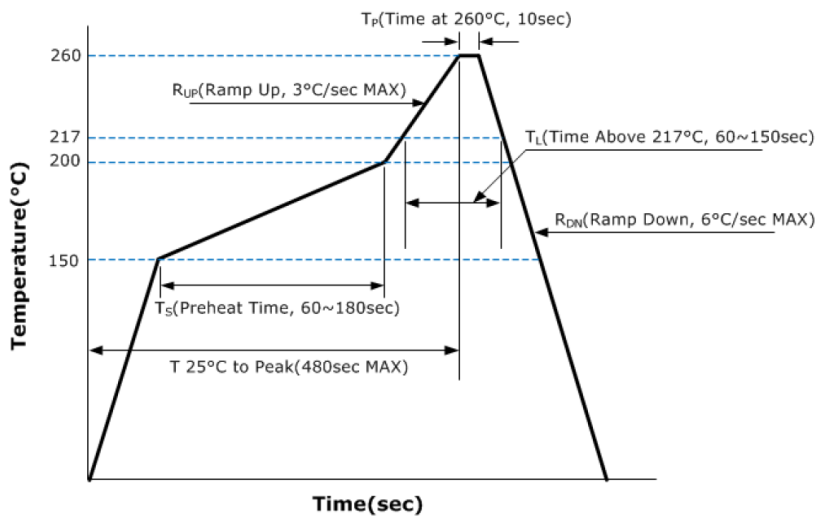

MARKING GUIDE

Frequency

VDD
3.3 : 3, 5.0 : 0

LINE 1 : SUNNY

LINE 2 : SCO-06X

LINE 2 : XX.XXXMHz

LINE 3 : ●YY MM

Year

Month