

DATA SHEET for LED

LY30240

Part No.	LY30240		
Emitted Color	Lens Color	Chip Material	
Yellow	Yellow Diffused	GaAsP/GaP	

Package Dimensions :

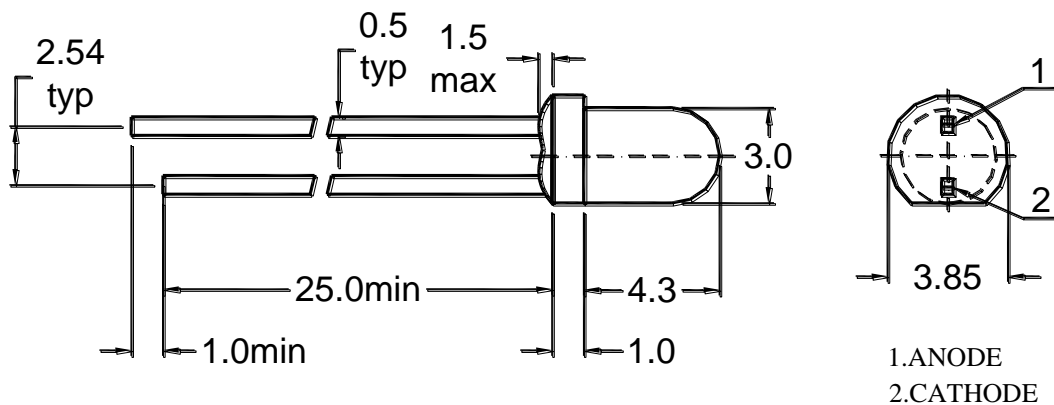

Note :

1. All dimensions are in millimeters(mm)
2. Tolerance is ± 0.25 mm unless otherwise noted

Absolute Maximum Rating of Each Segment (Ta = 25 °C)

Parameter	Symbol	Maximum Rating	Unit
Power Dissipation	P_d	60	mW
Pulse Forward Current (Duty 1/10 @ 1kHz)	I_{FP}	70	mA
Continuous Forward Current	I_F	20	mA
Reverse Voltage	V_R	5	V
Operation Temperature	T_{opr}	-30°C ~85°C	°C
Storage Temperature	T_{stg}	-40°C ~100°C	°C
Soldering Temperature	T_{sol}	260 \pm 5	°C

Note : Soldering Time ≤ 5 seconds

Electron-Optical Characteristics of Each Segment (Ta = 25 °C)

Parameter	Symbol	Min.	Typ.	Max.	Unit	Test Condition
Luminous Intensity	I _v		40		mcd	I _F =20 mA
Forward Voltage	V _F		2.0	2.5	V	I _F =20 mA
Reverse Current	I _R			20	μA	V _R =5V
Dominant Wavelength	λ _d		585		nm	I _F =20 mA
Peak Emission Wavelength	λ _p		588		nm	I _F =20 mA
Spectral Line Half Width	Δλ		30		nm	I _F =20 mA
Viewing Angle	2θ _{1/2}		40		deg	I _F =20 mA

Note :

- 1) The luminous intensity data and λ_p is survey values with the machine JF- II, JS-2000.
- 2) 2θ_{1/2} is the chip angle at which the luminous intensity half the axial luminous intensity.

Reliability Test Items and Conditions

Test Item	Test Conditions	Duration	Sample	Ac/Re
Temperature Cycle	-40°C(30 min.) ~ 25°C(5 min.) ~ 100°C(30 min.) ~ 25°C(5 min.)	50 cycles	100	0/1
High Temp. Storage	Ta=100°C	1,000 hours	100	0/1
Temp. & Humidity Test	Ta=85°C RH=85%	1,000 hours	100	0/1
Low Temp. Storage	Ta=-40°C	1,000 hours	100	0/1
Operating Life Test	Ta=25±5°C DC IF=20mA	1,000 hours	100	0/1
Solder Heat	Tsol=260±5°C, 10s	1 time	20	0/1

Precautions In Use

A. Lead frame Forming and Use

- 1) When forming leads ,the leads should be bent at a point at least 3mm from the base of epoxy. Lead forming should be done before soldering.
- 2) Do not apply any bending stress to the base of the lead. The stress to the base may damage the LEDs characteristics.
- 3) When mounting the LEDs onto a printed circuit board ,the holes on the circuit board should be exactly aligned with the leads of the LEDs.
- 4) Please avoid conditions which may cause the LED to corrode, tarnish or discolor. This corrosion or discoloration may cause difficulty during soldering operations. It is recommended that the LEDs be used as soon as possible.

5) Please avoid rapid transitions in ambient temperature, especially, in high humidity environments.

Notes :

- 1) Above specification may be changed without notice. We will reserve authority on material change for above specification.
- 2) When using this product, please observe the absolute maximum ratings and the instructions for the specification sheets. We assume no responsibility for any damage resulting from use of the product which does not comply with the instructions included in the specification sheets.

Typical Electro- Optical Characteristic Curves :

