

Features

- $\phi 3\text{mm}$ (T-1) all plastic mold type
- Colorless transparency lens

Features

- VCR, Camcorders
- Floppy disk drivers
- Optical detectors

Outline Dimensions

unit : mm

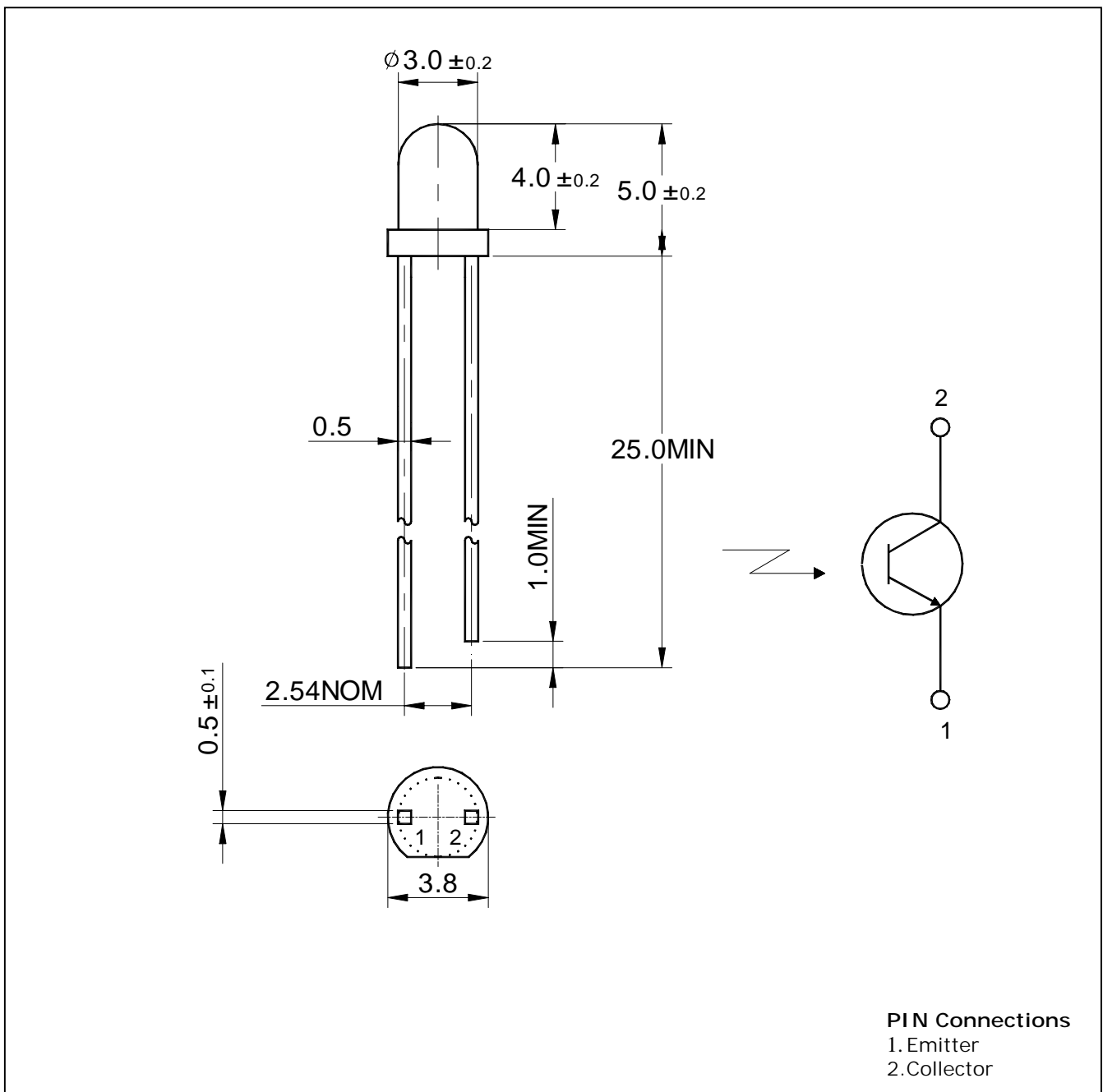

Absolute maximum ratings

Characteristic	Symbol	Ratings	Unit
Collector-Emitter Voltage	V_{CEO}	35	V
Emitter-Collector Voltage	V_{ECO}	6	V
Collector Current	I_C	20	mA
Collector Power Dissipation	P_D	75	mW
Operating Temperature	T_{opr}	-25 85	
Storage Temperature	T_{stg}	-30 100	
*1Soldering Temperature	T_{sol}	260 for 5 seconds	

*1.Keep the distance more than 2.0mm from PCB to the bottom of Photo TR package

Electrical Characteristics

Characteristic	Symbol	Test Condition	Min.	Typ.	Max.	Unit
Current Dark Current	I_{CEO}	$V_{CEO}=10V, E_e=0$	-	0.05	0.5	uA
*3Light Current	I_{CEL}	$V_{CE}=5V, E_e=1mW/cm^2$	-	4.5	-	mA
Current-Emitter Saturation Voltage	$V_{CE(sat)}$	$I_C=0.5mA, E_e=1mW/cm^2$	-	0.2	-	V
Switching Time	Rise Time	$V_{CC}=10V, I_C=1mA$ $R_1=100\Omega$	-	2.5	-	us
	Fall Time			3.8		
Spectral Sensitivity		-	700 ~ 1000			nm
Peak Sensitivity Wavelength	λ_p	-	-	880	-	nm
Half angle	$\theta_{1/2}$	$I_F=20mA$	-	± 20	-	deg

*1. Tolerance = $\pm 30\%$

Characteristic Diagrams

Fig. 1 $I_{CEL} - E_e$

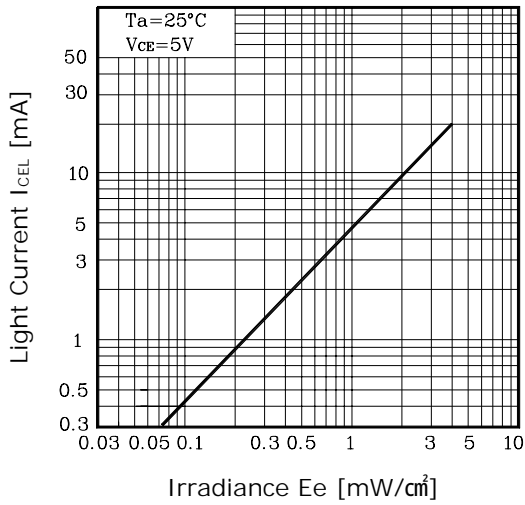

Fig. 2 $I_{CEL} - V_{CE}$

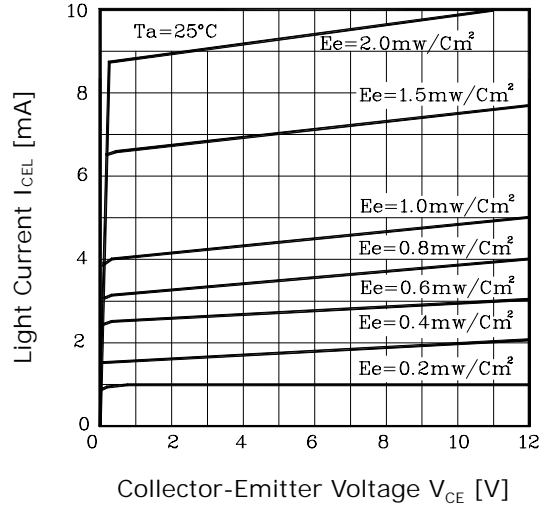

Fig. 3 $P_D - T_a$

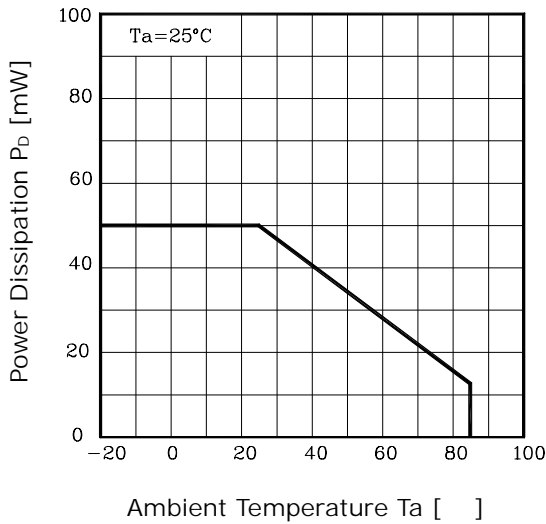

Fig. 4 $I_{CEO} - T_a$

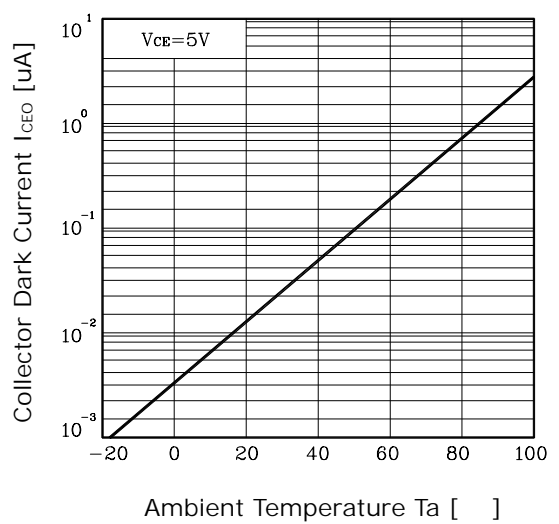

Fig. 5 Spectrum Sensitivity

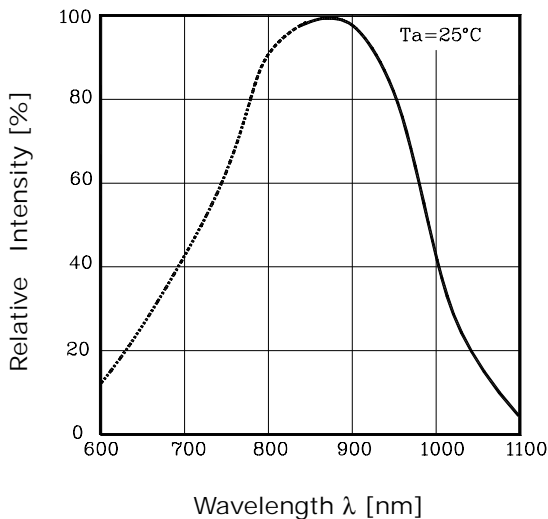

Fig. 5 Sensitivity Diagram

