

Carbon Dioxide (Tiny CO₂) Gas Sensor

Rev. 1.1

TG401 User Manual

The TG401 measuring carbon dioxide (chemical formula CO₂) is a NDIR (Non-Dispersive Infrared) gas sensor. As it is contactless, it has high accuracy and longer life than sensors having a different way. This sensor has been developed with standard gas and is efficiently calibrated using our state of the art gas sensor calibration technology. Furthermore, this sensor comes with Serial Communication (UART) and Analog Output. So, CO₂ density can be checked using these interfaces easily.

Features

- NDIR Gas Sensor
- High Precision
- Long Life Span, 5 years
- Compact Size, 32 x 19 mm
- RoHS Compliance

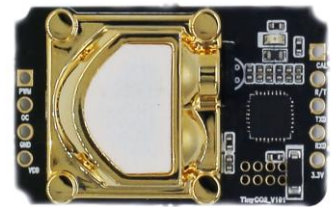

Model : TG401

Interfaces

- UART, 38400 Baud Rate
- PWM Output
- Analog Output

Specifications

Table 1. Electrical Specifications

Parameter	Symbol	Min	Typ.	Max	Unit	Notes
Regulated DC Power Supply is used, Test Condition : $V_{DD} = 5V$						
Power Supply	V_{DD}	4.9	5	5.1	V	
Current Consumption	I_{DD}	12	-	21	mA	ready state
	I_{DD}	100	-	210	mA	while gas measurement

* The noise on power supply may cause incorrect measurement.

Table 2. Sensor Specifications

Parameter	Symbol	Min	Typ.	Max	Unit	Notes
Measuring Range		0	-	5k	ppm	
Accuracy		±5% ±30ppm				Reading Value
Detection Limit		-	10	-	ppm	(Resolution @ 0ppm region)
Response Time	$t_{1/e}$	-	-	18	sec	
	t_{90}	-	-	30	sec	

Operating Temperature	T_O	0	-	50	°C	
Operating Humidity	H	0	-	95	%,RH	Non Condensing

Storage Temperature	T_S	-30	-	70	°C	
Storage Humidity	H	0	-	95	%,RH	Non Condensing

Table 3. UART Interface Specifications

Parameter	Symbol	Min	Typ.	Max	Unit	Notes
Recommended Request Time	T_{UR}	0.5	1	-	sec	
Transmitted Time	T_{UT}	-	2	-	sec	
Acceptable TTL Signal High Level	V_{HU}	2.31	3.3	5.25	V	TXD, RXD
Acceptable TTL Signal Low Level	V_{LU}	-	-	0.99	V	TXD, RXD

Table 4. Analog Output Specifications

Parameter	Symbol	Min	Typ.	Max	Unit	Notes
Analog Output Range	V_A	0	-	2500	mV	
Conversion Time	T_V	-	2	-	sec	

* The range of analog output depend on maximum value of measured ppm.

UART Interface

This sensor comes with a serial interface for user to read ppm values. Also, several commands are supported.

To use UART interface, refer to serial communication configuration in Table 5.

Table 5. Serial Communication Configuration

Baud Rate	38,400 bps
Stop Bits	1 bit
Parity Check	None
Data Length	8 bits
TTL Level	3.3V or 5V

If the communication configuration is set correctly, user will get the protocol message as mentioned below.

Table 6. Protocol Format

Byte	1	1	1	1	1	1	1	1	1	1	1	1
Value	D6	D5	D4	D3	D2	D1	<SP>	'p'	'p'	'm'	<CR>	<LF>

Table 7. Protocol Format Explanation

Value	Description
D6 ~ D1	Gas density is indicated as string, Maximum length is 6 bytes.
<SP>	Space : 0x20
'ppm'	'ppm' : 0x70 0x70 0x6D
<CR>	Carriage Return : 0x0D
<LF>	Line Feed : 0x0A

The number of <SP> between D6 and D1 will be different for different gas densities. So, user will get 'ppm' values in ASCII format, shown below.

To write commands, Follow the important points below to keep in mind while sending serial commands and refer to the examples given on pages 5.

- ① This protocol format conforms to ASCII format.
- ② Before send command, Enter command mode.
- ③ All commands should be delimited by <CR> <LF>.

Getting Started with UART Commands

User can communicate with sensor using PC software / terminal program or another device. Which supports serial communication on same baud rate as mentioned in serial interface specification. If user has connected their serial device correctly, they will receive string message from sensor. The message will be transmitted at intervals of about two seconds.

Example

```
RX> <SP>643<SP>ppm<CR><LF>
```

Example 1. ASCII Code Message

Example

```
RX> 20 36 34 33 20 70 70 6D 0D 0A
```

Example 2. HEX Code Message

Entry Command Mode

To use any command, sensor should be entered in command mode. To enter in command mode, user should send **ATTN<CR><LF>**. Otherwise, the commands will not be recognized by the sensor.

Example

```
TX> ATTN<CR><LF>  
RX> ATTN<CR><LF>  
RX> <ACK>
```

Example 3. ATTN Message

Exit Command Mode

To exit from the command mode, user should send **RUN<CR><LF>**. When user is not using serial interface, to continue with normal running mode.

Example

```
TX> RUN<CR><LF>  
RX> RUN<CR><LF>  
RX> <ACK>
```

Example 4. RUN Message

PWM Output

This sensor has PWM Output to read ppm value. To read ppm value, the PWM Output should be convert to ppm value. Refer to function 1.

$$C_{ppm} = \frac{5000 * (T_H - 2ms)}{(T_H + T_L - 4ms)}$$

Function 1. Formula for obtaining PPM from PWM Output

* C_{ppm} : CO2 level which calculated by PWM Output

* T_H : high level output time during cycle

* T_L : level output time during cycle

Table 8. PWM Format Explanation

Value	Description
CO2 Range	0 ~ 5000ppm
Cycle	1004ms ±5%
Cycle start high level output	'ppm' : 0x70 0x70 0x6D
The middle cycle	Carriage Return : 0x0D
Cycle end low level output	Line Feed : 0x0A

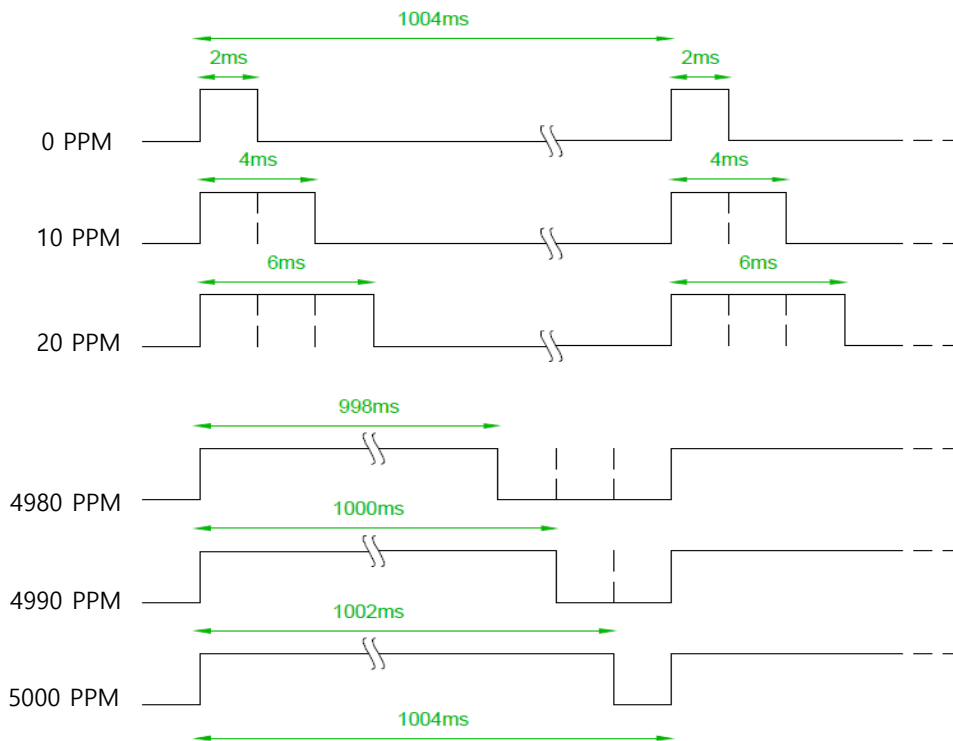

Picture 1. PWM Cycle

Analog Output

This sensor has analog output to read ppm value. To read ppm value, the analog voltage value should be convert to ppm value. Refer to Function 2.

$$ppm = \frac{V_{Analog\ Output}}{0.0005}$$

Function 2. Formula for obtaining PPM from Analog Output

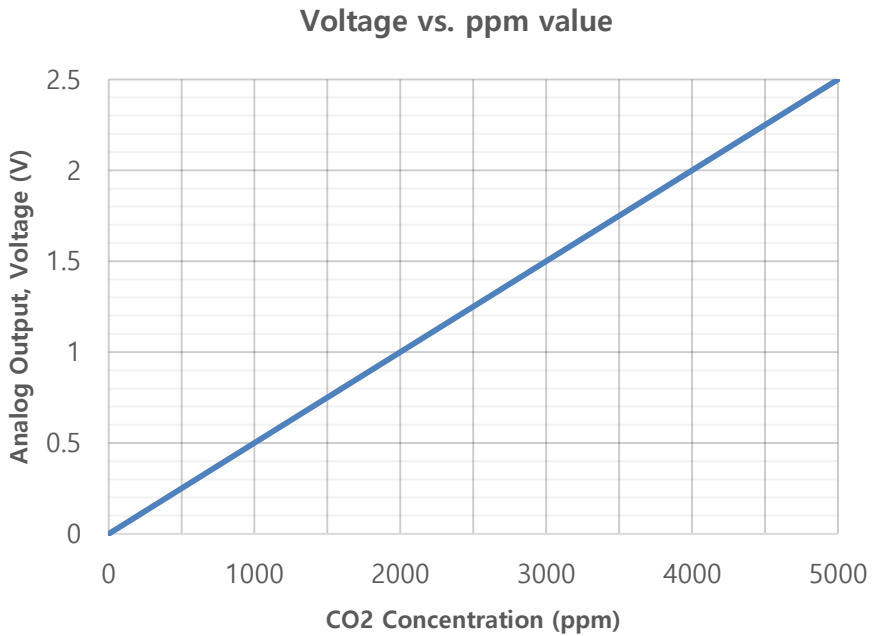

Graph 1. Voltage to ppm Graph

In case of analog output, the accuracy of ppm may be different when compared with other interface.

Package Dimension

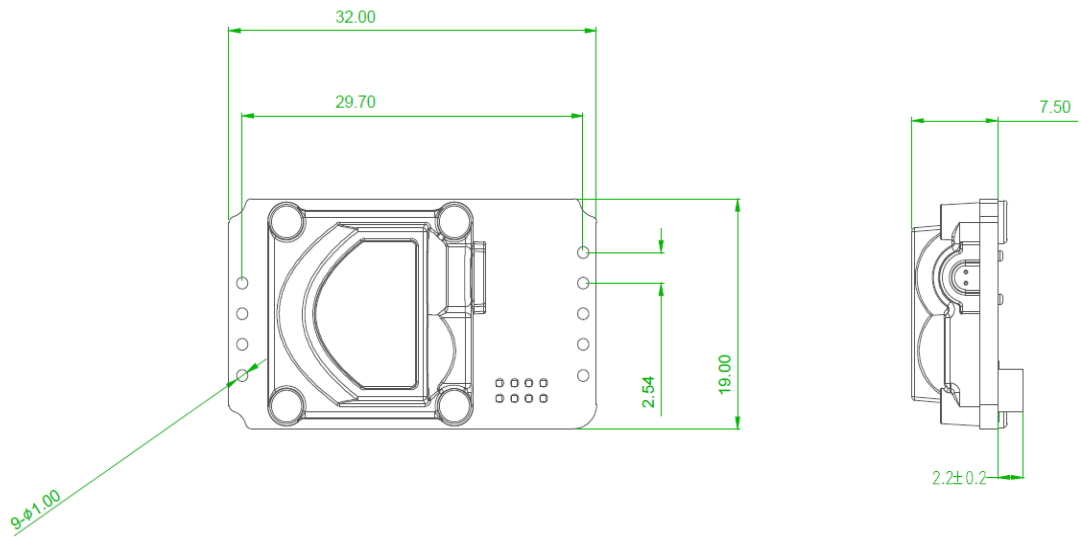

Dimension 1. Product Dimension

※ Caution : Do not attempt to reassemble or give physical stress while handling.

Pin Description - TOP

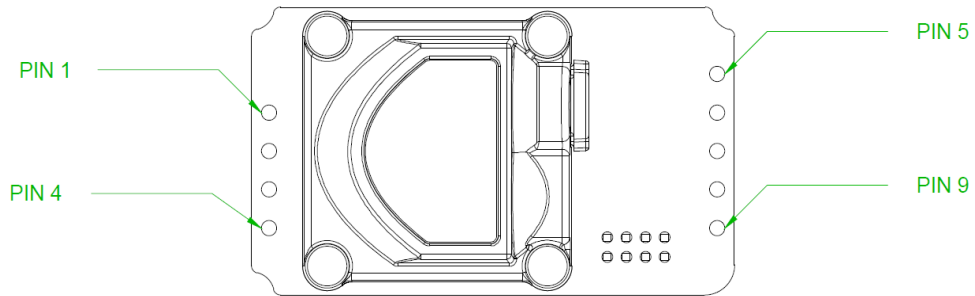

Table 9. Upper Pin Description

No.	Pin Assigned
1	PWM
2	-
3	GND
4	V_{DD}

Table 10. Lower Pin Description

No.	Pin Assigned
5	-
6	-
7	UART TXD →
8	UART RXD ←
9	Analog Output

※ Caution : Reserved pins should not be connected to anything.

Revision History

Table 11. Revision History

Revision	Description	Date	Author
1.0	Initial release	21 July 2018	DH Jeong
1.1	Add PWM Spec.	20 August 2018	DH Jeong



This document contains information of products and processes in development. All information provided here is subject to change without notice. Information in this document supersedes and replaces information previously supplied in any prior versions of this document.

We do not guarantee the performance of this device in case of disassembling, operating without complying with instructions in this document.

Contact your TRUEYES representative to obtain the latest forecast, schedule and specifications. Or It may be obtained by calling +82-2-2083-2377~8 or by visiting <http://www.trueyes.co.kr>

Copyright © 2018 TRUEYES Incorporated. All rights reserved.