

XGZP6161 Pressure Transducer

Feature

- Firm construction, Easy installation
- 0.5-4.5V output, Perfect performance.
- Advanced Anti-interference, wave protection
- Perfect Anti-shock, anti-overload, corrosion-resistant
- Isolation Diaphragm, Ceramic Sensor element
- Low cost for high volume application



Applications

- Water pump, frequency-alterable constant voltage water supply, building automatic control, Water Treatment system, Hydraulic pressure monitoring etc.,.
- HVAC controlling (Heating, Ventilation and Air Conditioning), Air conditioner, Refrigeration, process controlling, hydraulic pressure monitoring, etc.
- Other pressure measure and control of petroleum, chemi-industry, metallurgy, power station, hydrology, etc.,.

Introduction

XGZP6161 Pressure Transducer is high performance and low cost products. It is structured by Piezo-resistive ceramic pressure sensor as signal sensing element, adopt the special ASCII amplifier circuit and stainless steel housing, the XGZP6161 Transducer is integrally temperature compensated and linearity corrected, which effectively resist water hammer effect and transient over-voltage, etc. It can meet the requirement of measure and control under complex environment. Through strict component making, semi-finished product and all-finished product testing and aging, the Transducer is stable and reliable, having excellent consistency and sensitivity.

Pressure Range (100kPa=0.1mPa=1Bar≈14.5PSI)

Range	Unit	Range	Unit	Range	Unit
0 ~ 1	mPa	0 ~ 150	PSI	0 ~ 10	Bar
0 ~ 1.6	mPa	0 ~ 240	PSI	0 ~ 16	Bar
0 ~ 2	mPa	0 ~ 300	PSI	0 ~ 20	Bar
0 ~ 2.5	mPa	0 ~ 375	PSI	0 ~ 25	Bar
0 ~ 3	mPa	0 ~ 450	PSI	0 ~ 30	Bar

Performance Parameter

Item	Data	Unit
Accuracy(non-lin., rep. and hys.)	±1.0,±2.0	%Span
Zero Thermal Drift	±0.03	%FS/°C
Span Thermal Drift	±0.03	%FS/°C
Long Term Stability(1 Year)	±1	%Span
Insulation Impedance (250Vdc)	50	MΩ
Over pressure	2×	Rated
Burst Pressure	3×	Rated
Pressure Circulation(Zero- Span)	1	Million
Compensation Temp.	0 ~ 85/32~176	°C/°F
Operating Temp.	0 ~ 85/32~176	°C/°F
Storage Temp.	-40 ~ 125/-40~257	°C/°F
Housing Material	304 Stainless Steel	
Socket Connector	Plastic	
Protection Grade	IP65	
General condition:Power Input:3.3- 5.5VDC&Reference Temp.: (25±1)°C/(77±1.8)°F		

Dimension (Unit:mm/Inch)

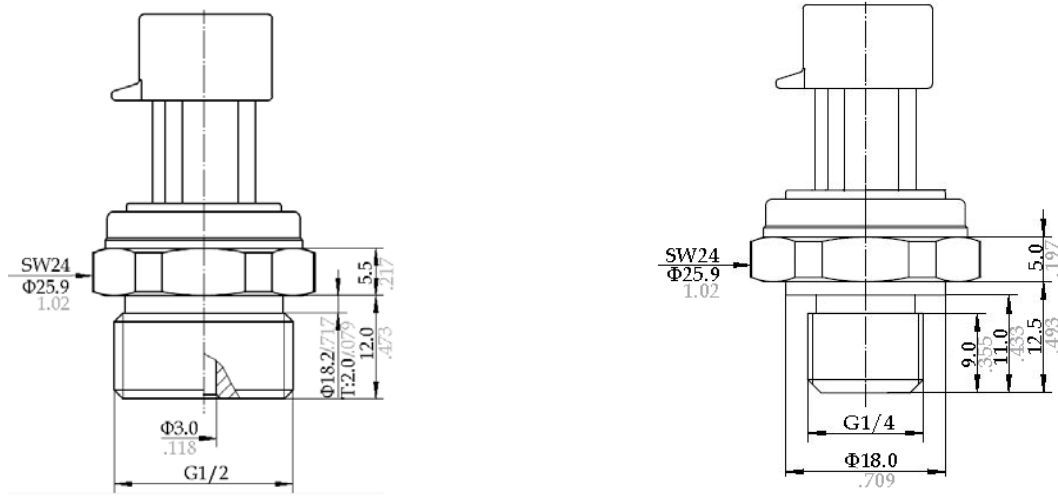

Electrical Connection&Definition

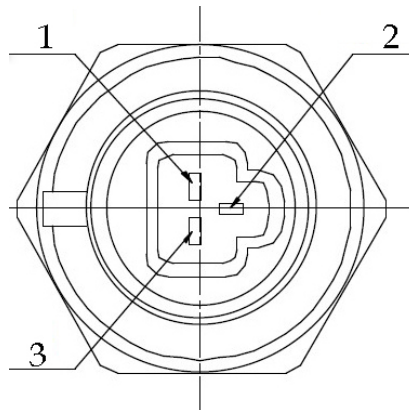

PIN Code	Cable	Elec-Definition(3wire)	Elec-Definition(2wire)
1	Black	Power: +V	Power: +V
2	Red	Signal:OUT	Signal:OUT
3	Yellow	GND	Null

Performance Characteristics

