

**Specifications for Approval**

**Customer** : \_\_\_\_\_

**Model name** : LMG1286410A-BMDSWW-NY REV: 3.0

**Description** : LIQUID CRYSRAL DISPLAY MODULE

DESIGN	CHECK	APPROVED

<p><b>Customer Approval</b></p>	<div style="margin-bottom: 10px;"> <input type="checkbox"/> <b>Accept</b> </div> <div style="margin-bottom: 10px;"> <input type="checkbox"/> <b>Reject</b> </div> <p><b>Comment:</b></p>   <p style="text-align: right;"><b>Approved by:</b></p>
---------------------------------	---



# CONTENTS

1. LCM MODULE NUMBERING SYSTEM
2. FEATURES
3. MECHANICAL SPECIFICATIONS
4. ELECTRICAL SPECIFICATIONS
5. POWER SUPPLY
6. ELECTRO-OPTICAL CHARACTERISTICS
7. TERMINAL FUNCTIONS AND BLOCK DIAGRAM
8. TIMING CHARACTERISTICS
9. INSTRUCTION SET
10. QUALITY SPECIFICATIONS
11. RELIABILITY
12. HANDLING PRECATION
13. OUTLINE DIMENSION

<b>MODEL</b>	<b>LMG1286410A-BMDSWW-NY</b>	<b>1/25</b>	<b>PRODUCT SPECIFICATIONS</b>	<b>REV:3.0</b>
--------------	------------------------------	-------------	-------------------------------	----------------

# 1. LCM MODULE NUMBERING SYSTEM

**PART NUMBER: LMax.....yB-CDEFGHI-JK**

**L: LONDA TECHNOLOGY**

**M: MODULE**

**A: DISPLAY CONTENTS                    C--- CHARACTER TYPE  
   G--- GRAPHIC TYPE  
   S---SEGMENT TYPE**

**x.....:                    CHARACTERS Vs. LINES FOR CM  
   COLUMNS Vs. ROWS FOR GM  
   SERIALS NUMBER FOR SM**

**y:                    DISTRIBUTE ACCORDING TO SIZE**

**B :                    VERSION OF PCB**

**C: LCD TYPE:**

**Y---YELLOW STN            G---GRAY STN            B---BLUE STN  
F---FSTN                    T---TN**

**D: POLARIZER TYPE:**

**R--- REFLECTIVE    T--- TRANSFLECTIVE  
M--- TRANSMISSIVE**

**E: VIEWING TEMPRETURE:**

**U--- 12:00            D--- 6:00            L--- 9:00            R--- 3:00**

**F: BACKLIGHT TYPE:**

**D---BOTTOM LED    S---SIDE LED            E--- EL            C--- CCFL  
N---NO BACKLIGHT**

**G: COLOR OF BACKLIGHT :**

**Y---YELLOW/GREEN    G--- GREEN            B--- BLUE  
W--- WHITE            O--- ORANGE            A--- AMBER**

**H:OPERATING TEMPRETURE:**

**N--- NORMAL,    W--- EXTENDED ,    X:ESPECIALLY EXTENDED**

**I: DENOTE DIFFERENT CHARACTER TABLE:**

**NORMAL ELLIPSIS, T--- TAB ,    G--- COG**

**-JK:**

**FOR CM:**

**J: IC TYPE: A--- KS0066U            B--- SPLC780**

**K: CHARACTER STOREROOM SEQUENCE NUMBER**

**FOR GM:**

**J: BACKLIGHT DRIVER**

**Y--- WITH                    N--- WITHOUT**

**K: DC-DC CONVERTER**

**Y--- WITH                    N--- WITHOUT**

**MODEL**

**LMG1286410A-BMDSWW-NY**

**2/25**

**PRODUCT SPECIFICATIONS**

**REV:3.0**

## 2. FEATURES

The features of LCD are as follows

- \* Display mode : STN, Negative, Transmissive
- \* Color : Display dot : White  
Background: Blue
- \* Display format : 128 Dots X 64 Dots
- \* Interface Input Data : 8-Bit
- \* Driving Method : 1/64 Duty, 1/9 Bias
- \* Viewing Direction : 6 O'clock
- \* Backlight : LED Unit (White )
- \* Drive IC : SBN6400 & SBN0064

## 3. MECHANICAL SPECIFICATIONS

Item	Specification	Unit
Module Size	75.00(W) x 55.0(H) x 9.00(T)	mm
Number of Dots	128(W) x 64(H) Dots	mm
Viewing Area	60.00(W) x 32.00(H)	mm
Effective display area	55.01(W) x 27.49(H)	mm
Dot Size	0.40(W) x 0.40(H)	mm
Dot Pitch	0.43(W) x 0.43(H)	mm

## 4. ELECTRICAL SPECIFICATIONS

4-1 ABSOLUTR MAZIMUM RATINGS (Ta = 25 °C)

Item	Symbol	Standard Value			Unit
		Min.	Typ.	Max.	
Supply Voltage For Logic	$V_{DD} - V_{SS}$	0	-	5	V
Supply Voltage For LCD Drive	$V_{OP} = V_{DD} - V_0$	0	-	9	V
Input Voltage	V1	$V_{SS}$	-	$V_{DD}$	V
Operating Temp.	Top	-20	-	+70	°C *
Storage Temp.	Tst	-30	-	+80	°C

\*. NOTE: The response time will be extremely slow when the operating temperature is around -20°C, and the back ground will become darker at high temperature operating.

MODEL	LMG1286410A-BMDSWW-NY	3/25	PRODUCT SPECIFICATIONS	REV:3.0
-------	-----------------------	------	------------------------	---------

#### 4-2 ELECTRICAL CHARACTERISTICS

Item	Symbol	Test Condition	Min.	Typ.	Max.	Unit
Logic supply Voltage	$V_{DD} - V_{SS}$	-	4.5	5.0	5.5	V
LCD Drive	$V_{OP}=V_{DD} - V_0$		-	9.0	-	V
Input Voltage	"H" Level	$V_{DD}=5.0V \pm 5\%$	$0.8 V_{DD}$		$V_{DD}$	V
	"L" Level		0		$0.2V_{DD}$	V
Frame Frequency	fFLM	$V_{DD} = 5.0V$	65	78	85	Hz
Current Consumption	IDD	$V_{DD} = 5.0V$ $V_{DD}-V_0=9.0V$ $V/R=160Kohm$		1.60	3.0	mA

#### 4-3. BACKLIGHT

##### 4-3-1. Absolute Maximum Ratings

Item	Symbol	Condition	Min.	Typ.	Max	Unit
Forward Current	IF	$T_a = 25^\circ C$	-	40	60	mA
Reverse Voltage	VR		-	-	4.2	V
Power Dissipation	PD	$T_a = 25^\circ C$	-	-	300	mW

##### 4-3-2. Opto-electronic Characteristics

Item	Symbol	Condition	Min.	Typ.	Max	Unit
Forward Voltage	VF	$T_a = 25^\circ C$ $IF = 40mA$	-	5.0	5.5	V
Luminous	-		800	-	-	cd/m <sup>2</sup>

MODEL	LMG1286410A-BMDSWW-NY	4/25	PRODUCT SPECIFICATIONS	REV:3.0
-------	-----------------------	------	------------------------	---------

## 5. POWER SUPPLY



※  $V_{DD} - V_0 = \text{Operating voltage for LCD}$

MODEL

LMG1286410A-BMDSWW-NY

5/25

PRODUCT SPECIFICATIONS

REV:3.0

## 6. ELECTRO – OPTICAL CHARACTERISTICS

Item	Symbol	Temp.	Min.	Typ.	Max.	Unit	Conditions	Note
Viewing Angle	$ \theta_2 - \theta_1 $	25°C	30	80	-	Deg.	-	1,2
	$\Phi$		60	85	-			
Contrast Ratio	Cr	25°C	2	5.3	5.9	-	$\theta = 0^\circ$ $\Phi = 0^\circ$	3
Response Time(rise)	Tr	25°C	-	91	250	ms	$\theta = 0^\circ$ $\Phi = 0^\circ$	4
		0°C	-	950	1150			
Response Time(fall)	Tf	25°C	-	151	250	ms	$\theta = 0^\circ$ $\Phi = 0^\circ$	4
		0°C	-	950	1150			

Note1 . Definition of Angle  $\theta$  &  $\Phi$

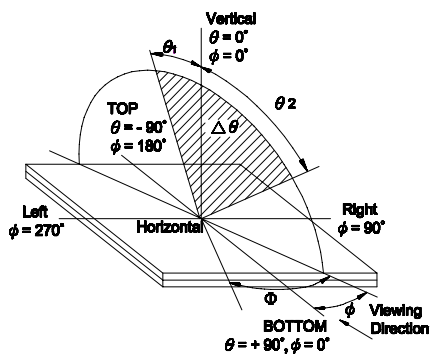

Note2. Definition of Viewing Angle  $\theta_1$  &  $\theta_2$

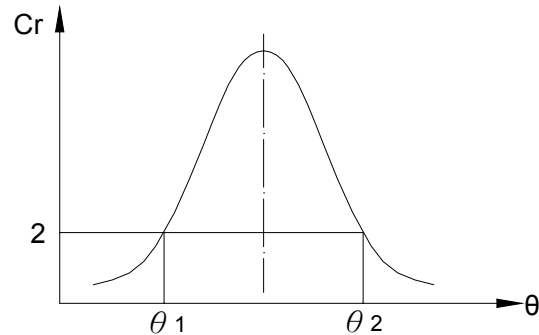

Note3 . Definition of Contrast Cr

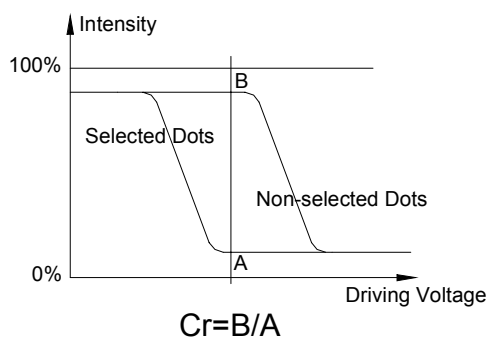

Note4. Definition of Optical Response

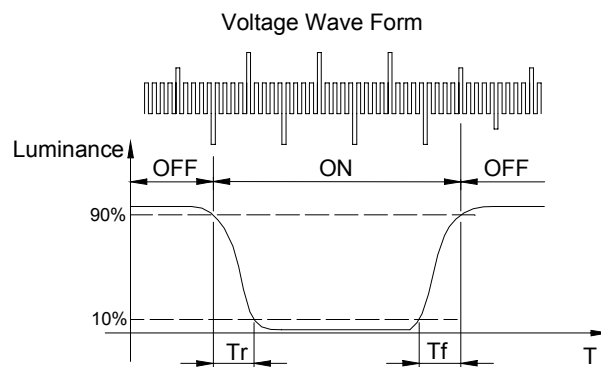

MODEL

LMG1286410A-BMDSWW-NY

6/25

PRODUCT SPECIFICATIONS

REV:3.0

## 7.TERMINAL FUNCTIONS AND BLOCK DIAGRAM

### 7-1.INTERFACE PIN FUNCTION DESCRIPTION

NO.	SYMBOL	DESCRIPTION
1	VDD	POWER SUPPLY FOR LOGIC AND LCD
2	VSS	GROUND
3	V0	OPERATING VOLTAGE FOR LCD
4	DB0	DATA BUS
5	DB1	DATA BUS
6	DB2	DATA BUS
7	DB3	DATA BUS
8	DB4	DATA BUS
9	DB5	DATA BUS
10	DB6	DATA BUS
11	DB7	DATA BUS
12	/CS1	CHIP SELECT OF IC1 (LOW EFFECTIVE)
13	/CS2	CHIP SELECT OF IC2 (LOW EFFECTIVE)
14	/RST	RESET SIGNAL(LOW EFFECTIVE)
15	R/W	READ/WRITE SELECT
16	RS	DATA/INSTRUCTION SELECT
17	E	ENABLE SIGNAL
18	VEE	NEGATIVE VOLTAGE OUTPUT/INPUT
19	K	BACKLIGHT-
20	A	BACKLIGHT+

### 7-2.BLOCK DIAGRAM

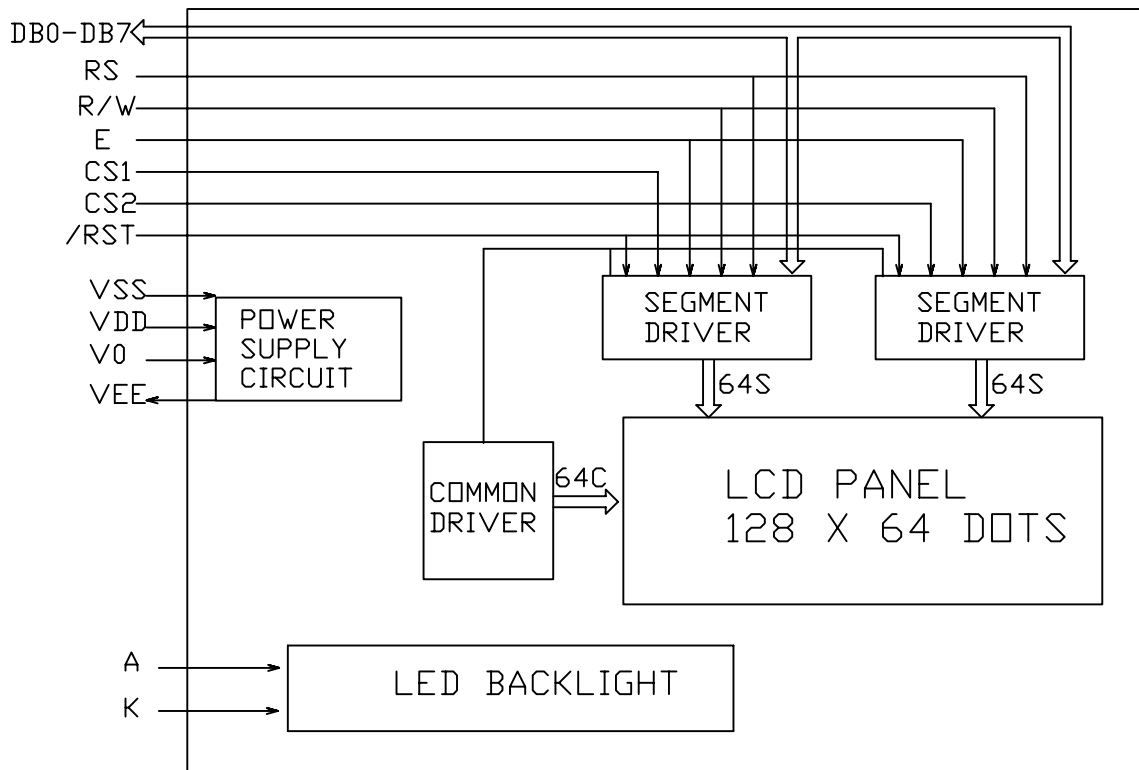

MODEL

LMG1286410A-BMDSWW-NY

7/25

PRODUCT SPECIFICATIONS

REV: 3.0



## 8. TIMING CHARACTERISTICS

Characteristic	Symbol	Min	Typ	Max	Unit
E cycle	$t_C$	1000	-	-	ns
E high level width	$t_{WH}$	450	-	-	ns
E low level width	$t_{WL}$	450	-	-	ns
E rise time	$t_R$	-	-	25	ns
E fall time	$t_F$	-	-	25	ns
Address set-up time	$t_{ASU}$	140	-	-	ns
Address hold time	$t_{AH}$	10	-	-	ns
Data set-up time	$t_{DSU}$	200	-	-	ns
Data delay time	$t_D$	-	-	320	ns
Data hold time (write)	$t_{DHW}$	10	-	-	ns
Data hold time (read)	$t_{DHR}$	20	-	-	ns

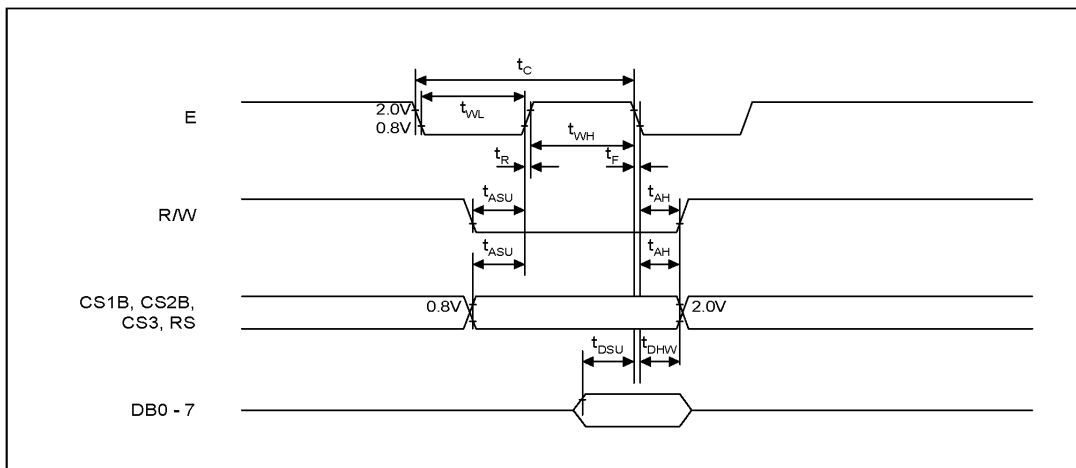

MPU Write Timing

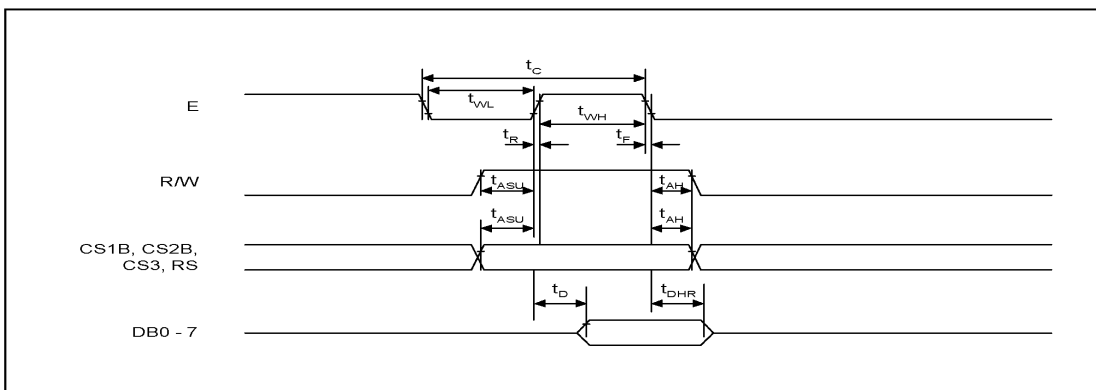

MPU Read Timing

MODEL	LMG1286410A-BMDSWW-NY	8/25	PRODUCT SPECIFICATIONS	REV:3.0
-------	-----------------------	------	------------------------	---------

## 9. INSTRUCTION SET

### 9-1. Function of Each Block

Both input register and output register are provided to interface with MPU of which The speed is different from that of internal operation. The selection of these registers Registers depend on the combination of R/W and D/I signals.

Table1. Register selection

D/I	R/W	Operation
1	1	Read data out of output register as internal operation (Display data RAM to output register)
1	0	Writes data into register as internal operation (Input register to display data RAM)
0	1	Busy check. Read of status data
0	0	Instruction

#### (1) Input Register

Input register is used to store Data temporarily before writing it into display data RAM. The data from MPU is written into input register, then into display data RAM Automatically by internal operation.

When chip select signal is in the active mode and D/I and R/W select the input Register as shown in table1, Data is latched at the fall of "E" signal.

#### (2) Output register

The output register is used to store data temporarily that is read from display data RAM. To read out the data from output register. Chip select signal should be in the Active mode and both D/I and R/W should be "1". With the read instruction, data stored in the output register is output while "E", the display data at the indicated address is latched into the output register and address is increased by 1. The contents in the output register is rewritten by read instructions, but are held by address set instruction, ect.

Therefore, the data of the specified address can not be output with read display Instruction, right after the address is set, but can be output at the second read of data. That is to say, on dummy read is necessary, Fig 9-1. Shows the CPU read timing.

MODEL	LMG1286410A-BMDSWW-NY	9/25	PRODUCT SPECIFICATIONS	REV:3.0
-------	-----------------------	------	------------------------	---------

## 9. INSTRUCTION SET (Continued)

### 9-1. Function of Each Block (Continued)

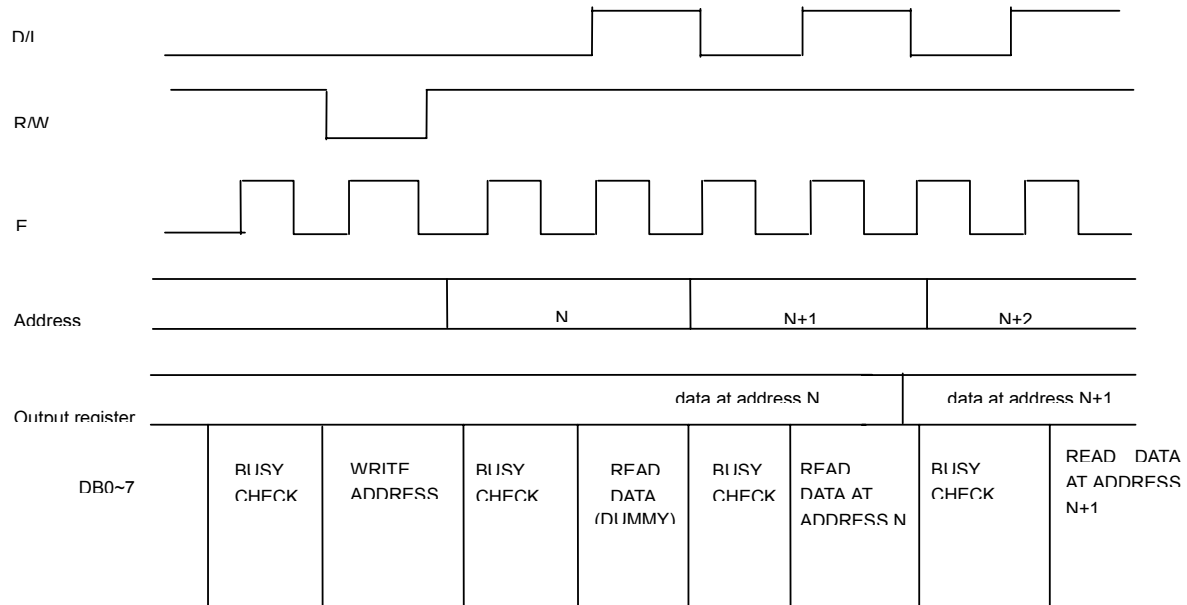

9-1. CPU read timing

#### 9-1-2. Busy flag

"1" of busy flag indicates that KS0108B is on the move and any instruction except status read instruction can not be accepted the value of the busy flag is read out on DB7 by the status read instruction make sure that the busy flag is reset("0") before The issue of instruction.

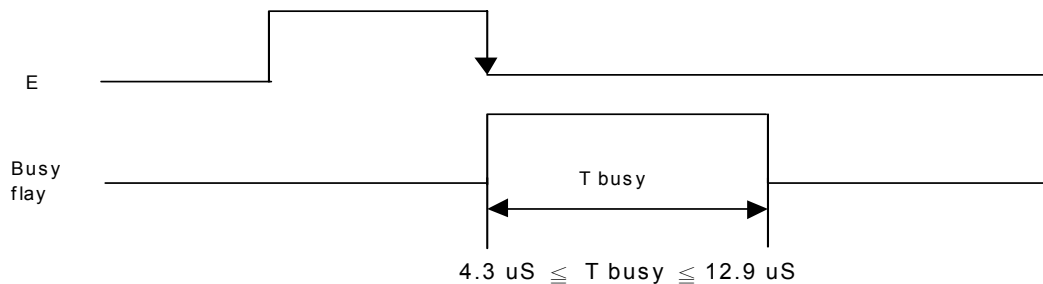

#### 9-1-3. Display on/off flip flop

Display on/off flip flop selects one of two states, on state and off state of segments, the Display data corresponding to that in RAM is output to the segments. On the other hand, The display data at all segments disappear in off state independent of ehte data in RAM. It is controlled by display on/off instruction "0" of RST signal sets the segments in off state, The status of the flip flop is output to DB5 by status read instruction. Display on/off Instruction does not inflence data in RAM.

## 9. INSTRUCTION SET (Continued)

### 9-1-4. Display start register

The register specifies A line in RAM which corresponds to the top line of LCD panel, When displaying contents in display data RAM on the LCD panel. It is used for scrolling Of the screen. 6-bit display start line information is written into this register by display Start the display, the information in this register is transferred to Z address, and the Z Address counter is preset.

### 9-1-5. X, Y address counter

This is 9 bit counter which designates address of internal display data RAM, X address Counter of upper 3 bits and Y address counter of lower 6 bits should be set each Address by respective instruction.

#### (1). X address counter

Ordinary register with no count functions. An address is set in by instruction.

#### (2). Y address counter

An address is set in by instruction and it is increased by 1 automatically by R/W Operations of display data. The address counter loops the value of 0 to 63 count.

### 9-1-6. Display data RAM

Dot data for display is stored in this RAM 1 bit data of this RAM corresponds to light on (data=1) and light off (data=0) of 1 dot in the display panel.

### 9-1-7. Reset

The system can initialized by setting RST terminal at "low" level when turning power on.

#### (1) Display off

#### (2) Set display start line register 0 line.

When RST is in low level, any instruction except status read can not be accepted, Therefore, carry out other instruction after making sure that DB4="0" (clear reset) And DB7="0" (ready) by status read instruction the conditions of power supply at Initial power up are as follows.

MODEL	LMG1286410A-BMDSWW-NY	11/25	PRODUCT SPECIFICATIONS	REV:3.0
-------	-----------------------	-------	------------------------	---------

## 9. INSTRUCTION SET (Continued)

### 9-1-7. Reset (Continued)

Item	Symbol	Min.	Typ.	Max.	Unit
Reset time	tRST	1.0	–	–	uS
Rise time	tr	–	–	200	uS

Do not fail to set the system again because reset during operation may destroy the data in all the register except on/off register and in RAM

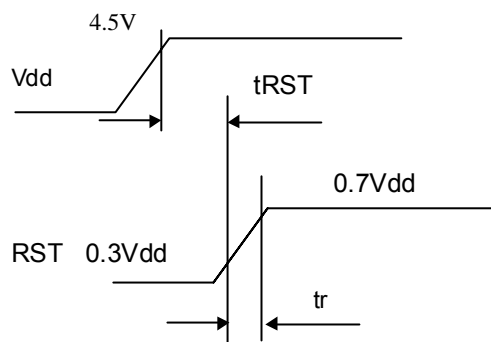

### 9-2. Display control instructions

Table 2 shows the instructions. Read/write (R/W) signal, data instruction (D/I) signal and data bus signal (DB0 to DB7) are also called instructions because the internal operation depends on the signal from MPU generally, there are following three kinds of instructions.

- 1) Instruction to give address in the internal RAM
- 2) Instruction to transfer data from/to the internal RAM
- 3) Other instructions.

In general use, the instruction "2)" are used most frequently, but, since Y address of the internal RAM is increased by 1 automatically after writing (reading) data, the program can be lessened, during the execution of an instruction, the system can not accept other instructions than status read instruction, send instruction from MPU after making sure if the busy flag is "0", which is the proof an instruction is not being executed.

## 9. INSTRUCTION SET (Continued)

Table 2

Function	D / I	R / W	D B 7	D B 6	D B 5	D B 4	D B 3	D B 2	D B 1	D B 0	Description
Display On/Off	0	0	0	0	1	1	1	1	1	0/1	Controls the on/off display RAM data and internal status are not affected. 0 : off ; 1: on.
Set Address	0	0	0	1	Y address (0 ~ 63)						Sets the Y address in the Y address counter.
Set Page (X address)	0	0	1	0	1	1	1	Page(0~7)			Sets the X address in the X address register.
Display Start Line	0	0	1	1	Display start line (0~63)						Indicates the display data RAM Displayed at the top of the screen.
Status Line	0	1	B U S Y	0	O N / O F F	R E S E T	0	0	0	0	Read status: BUSY : 0: Ready 1: In operation ON/Off 0: Display ON 1: Display Off RESET 0: Normal 1: Reset
Write display Data	1	0	Write Data								Writes data (DB0~7) into display Data RAM. After writing instruction, Y address is increased by 1 automatically.
Read display Data	1	1	Read Data								Reads data (DB0~7) into display data RAM to the data bus.

## 9. INSTRUCTION SET (Continued)

### 9-2-1. Display on/off

	R/W	D/I	DB7	DB6	DB5	DB4	DB3	DB2	DB1	DB0
CODE	0	0	0	0	1	1	1	1	1	D

The display data appears when dis 1 and disappears when D is 0  
 Through the data is not on the screen whdth D = "0", it remains in the  
 Display data RAM, there fore, you can make it appear by changing  
 D = "0" into D = "1"

### 9-2-2. Display start line

	R/W	D/I	DB7	DB6	DB5	DB4	DB3	DB2	DB1	DB0
CODE	0	0	1	1	A	A	A	A	A	A

Z address AAAAAA (binary) of the display data RAM is set at the  
 Display start line register and displayed at the top of the screen fig. 8-2  
 Are the examples of display when the start line = 0 ~ 3.

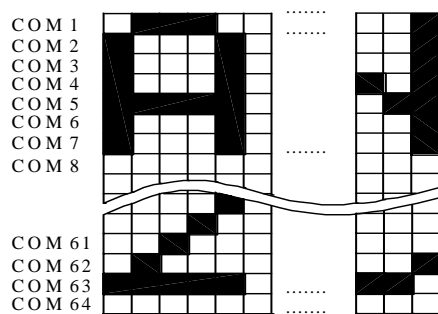

Start line = 0

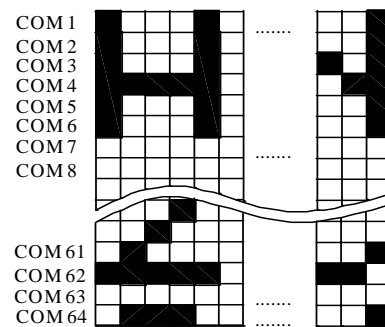

Start line = 1

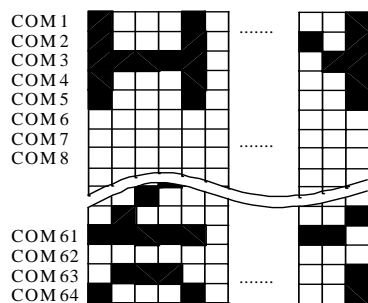

Start line = 2

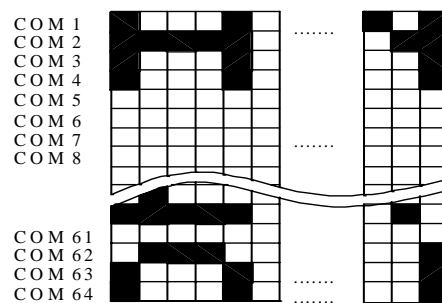

Start line = 3

### 9. INSTRUCTION SET (Continued)

#### 9-2-3. Set page (X address)

	R/W	D/I	DB7	DB6	DB5	DB4	DB3	DB2	DB1	DB0
CODE	0	0	1	0	1	1	1	A	A	A

X address AAA ( binary) of the display data RAM is set at the X address register. After that, writing or reading to or from MPU is executed in this specified page until the next page is set.

#### 9-2-2. Set Y address

	R/W	D/I	DB7	DB6	DB5	DB4	DB3	DB2	DB1	DB0
CODE	0	0	0	1	A	A	A	A	A	A

Y address AAAAAA (binary) of the display data RAM is set at the Address counter. After that, Y address counter is increased by 1 every time the data is written or read to or from MPU.

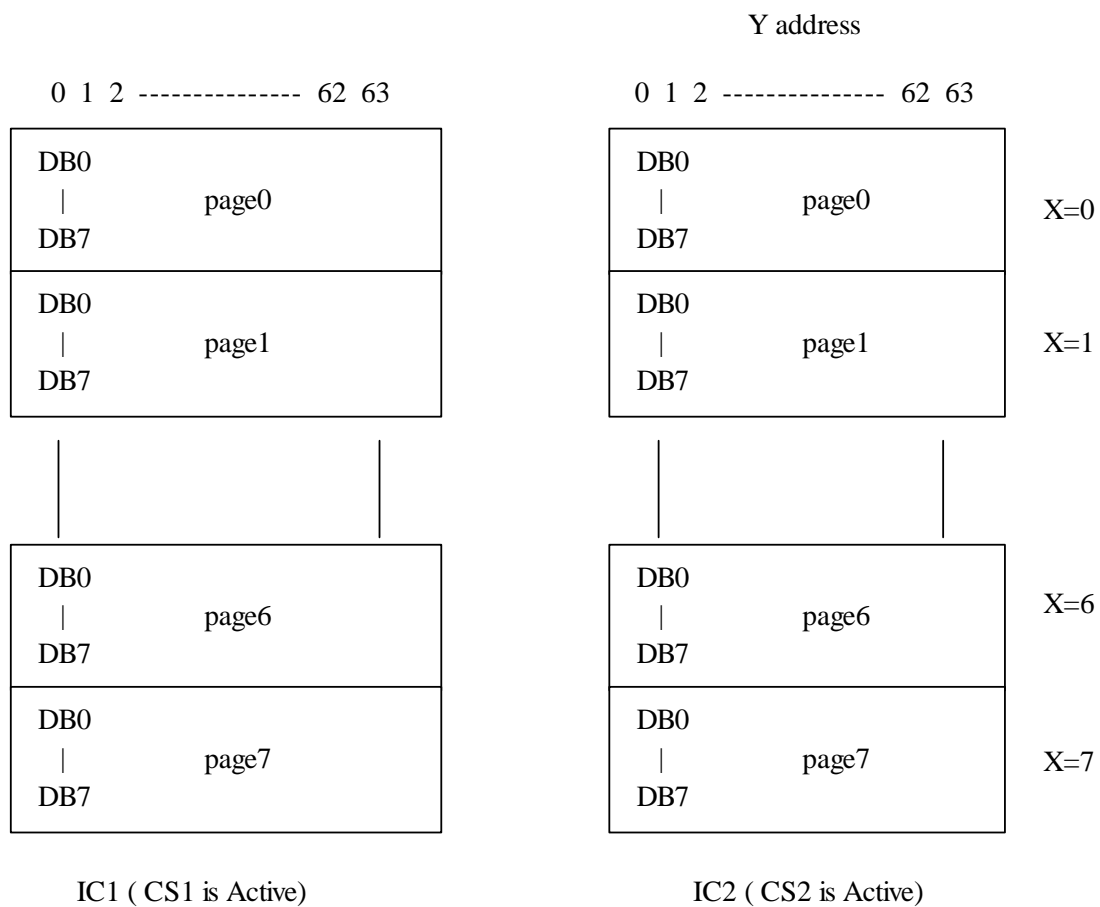



## 9. INSTRUCTION SET (Continued)

### 9-2-5. Status read

	R/W	D/I	DB7	DB6	DB5	DB4	DB3	DB2	DB1	DB0
CODE	1	0	Busy	0	On/Off	Reset	0	0	0	0

**Busy** : When "Busy" is "1". The LSI is in internal operation. On instructions are accepted while busy is "1". So you should make sure that busy is "0" before writing the next instruction.

**On/Off** : This bit shows the display conditions.

When On/Off is "1", the display is in off condition.

When On/Off is "0", the display is on condition.

**Reset** : Reset = "1" shows that the system is being initialized. In this condition, any instructions except status read instruction cannot be accepted.

Reset = "0" shows that initializling has finished and the system is in the usual operation.

### 9-2-6. Write display data

	R/W	D/I	DB7	DB6	DB5	DB4	DB3	DB2	DB1	DB0
CODE	0	1	A	A	A	A	A	A	A	A

Write 8-bit data AAAAAAAAA (binary) into the display data RAM then Y address is increased by 1 automatically.

### 9-2-7. Write display data

	R/W	D/I	DB7	DB6	DB5	DB4	DB3	DB2	DB1	DB0
CODE	1	1	A	A	A	A	A	A	A	A

Read out 8-bit data AAAAAAAAA (binary) from the display data RAM then Y address is increased by 1 automatically.

One dummy read is necessary soon after the address setting.

## 10. QUALITY SPECIFICATIONS

### 10 - 1. LCM Appearance and Electric inspection Condition

1. Inspection will be done by placing LCM 30cm away from inspector's eyeballs under normal illumination.

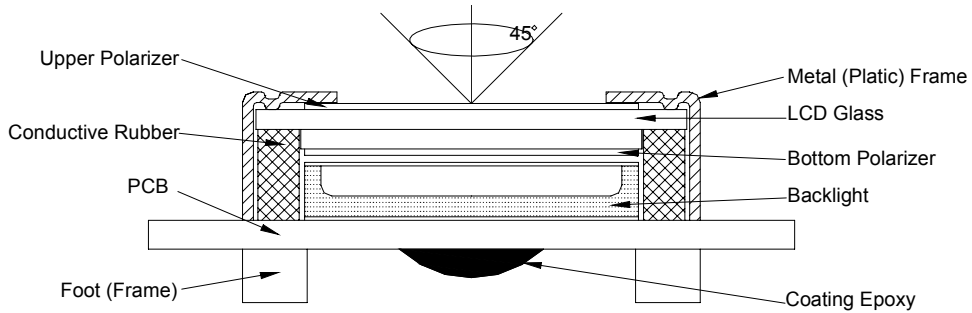

2. View Angle: with in 45° around perpendicular line.

### 10 - 2. Definition

#### 1. COB

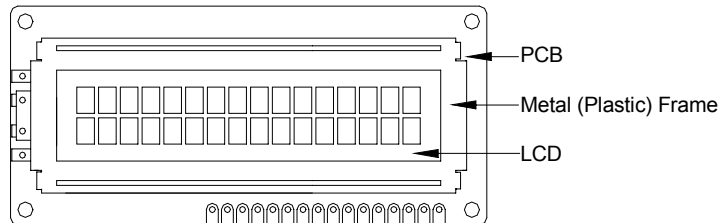

#### 2. Heat Seal

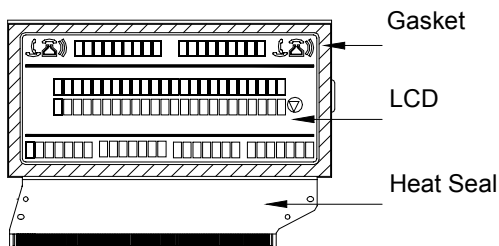

#### 3. TAB and COG

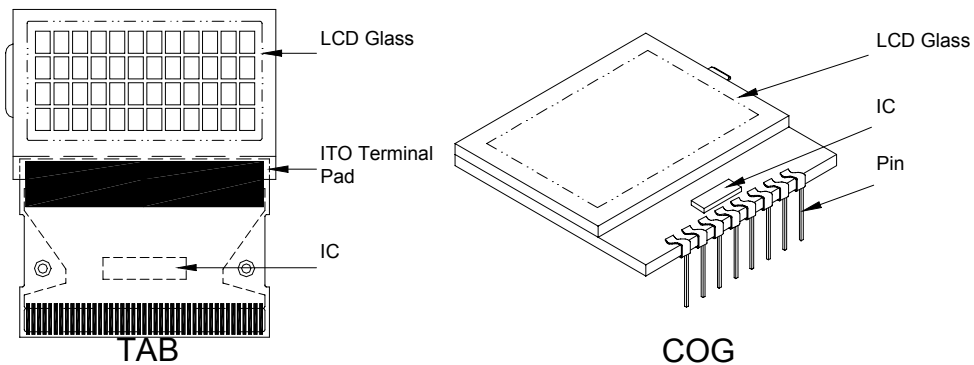

MODEL

LMG1286410A-BMDSWW-NY

17/25

PRODUCT SPECIFICATIONS

REV:3.0

## 10. QUALITY SPECIFICATIONS (Continued)

### 10-3. Sampling Plan and Acceptance

#### 1. Sampling Plan

MIL - STD - 105E ( || ) ordinary single inspection is used.

#### 2. Acceptance

Major defect: AQL = 0.25%

Minor defect: AQL = 0.65%

### 10-4. Criteria

#### 1. COB

Defect	Inspection Item	Inspection Standards	
Major	PCB copper flakes peeling off	Any copper flake in viewing Area should be greater than $1.0\text{mm}^2$	Reject
Major	Height of coating epoxy	Exceed the dimension of drawing	Reject
Major	Void or hole of coating epoxy	Expose bonding wire or IC	Reject
Major	PCB cutting defect	Exceed the dimension of drawing	Reject

#### 2. SMT

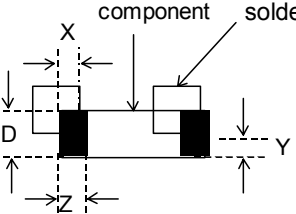
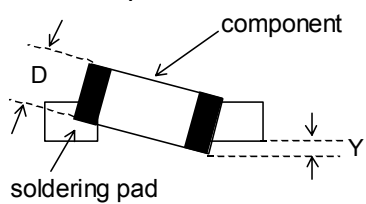
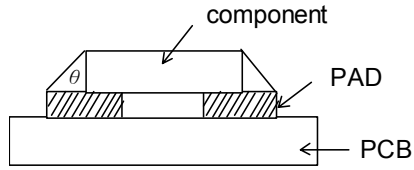
Defect	Inspection Item	Inspection Standards	
Minor	Component marking not readable		Reject
Minor	Component height	Exceed the dimension Of drawing	Reject
Major	Component solder defect (missing , extra, wrong component or wrong orientation)		Reject
Minor	<p>Component position shift</p> 	$X < 3/4Z$ $Y > 1/3D$	Reject Reject
Minor	<p>Component tilt</p> 	$Y > 1/3D$	Reject
Minor	<p>Insufficient solder</p> 	$\theta \leq 20^\circ$	Reject

MODEL LMG1286410A-BMDSWW-NY

18/25

PRODUCT SPECIFICATIONS

REV:3.0

## 10. QUALITY SECIFICATIONS (Continued)

### 10-4. Criteria (Continued)

#### 3. Metal (Plastic) Frame

Defect	Inspection Item	Inspection Standards		
Major	Crack / breakage	Anywhere		Reject
Minor	Frame Scratch	W	L	Acceptable of Scratch
		$w < 0.1\text{mm}$	Any	Ignore
		$0.1 \leq w < 0.2\text{mm}$	$L \leq 5.0\text{mm}$	2
		$0.2 \leq w < 0.3\text{mm}$	$L \leq 3.0\text{mm}$	1
		$w \geq 0.3\text{mm}$	Any	0
Note : 1. Above criteria applicable to scratch lines with distance greater than 5mm. 2. Scratch on the back side of frame (not visible) can be ignored .				
Minor	Frame Dent , Prick $\Phi = \frac{L + W}{2}$			Acceptable of Dents / Pricks
		$\Phi \leq 1.0\text{mm}$		2
		$1.0 < \Phi \leq 1.5\text{mm}$		1
		$1.5\text{mm} < \Phi$		0
Note : 1. Above criteria applicable to any two dents / pricks with distance greater than 5mm 2. Dent / prick on the back side of frame (not visible) can be ignored				
Minor	Frame Deformation	Exceed the dimension of drawing		
Minor	Metal Frame Oxidation	Any rust		

#### 4. Flexible Film Connector (FFC)

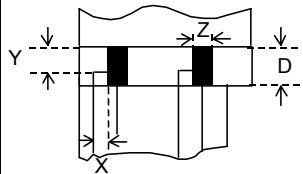
Defect	Inspection Item	Inspection Standards	
Minor	Tilted soldering	Within the angle $+5^\circ$	Acceptable
Minor	Uneven solder joint /bump		Reject
Minor	Hole $\Phi = \frac{L + W}{2}$	Expose the conductive line	Reject
		$\Phi > 1.0\text{mm}$	Reject
Minor	Position shift 	$Y > 1/3D$	Reject
		$X > 1/2Z$	Reject

## 10. QUALITY SPECIFICATIONS (Continued)

### 10-4. Criteria (Continued)

#### 5. Screw

Defect	Inspection Item	Inspection Standards	
Major	Screw missing/loosen		Reject
Minor	Screw oxidation	Any rust	Reject
Minor	Screw deformation	Difficult to accept screw driver	Reject

#### 6. Heatseal 、TCP 、FPC

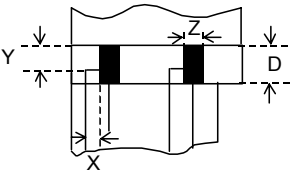
Defect	Inspection Item	Inspection Standards	
Major	Scratch expose conductive layer		Reject
Minor	HS Hole $\Phi = \frac{L+W}{2}$	$\Phi > 0.5\text{mm}$	Reject
Major	Adhesion strength	Less than the specification	Reject
Minor	Position shift 	$Y > 1/3D$	Reject
		$X > 1/2Z$	Reject
Major	Conductive line break		Reject

#### 7. LED Backing Protective Film and Others

Defect	Inspection Item	Inspection Standards	
Minor	LED dirty, prick	Acceptable number of units	
		$\Phi \leq 0.10\text{mm}$	Ignore
		$0.10 < \Phi \leq 0.15\text{mm}$	2
		$0.15 < \Phi \leq 0.2\text{mm}$	1
		$\Phi > 0.2\text{mm}$	0
The distance between any two spots should be $\geq 5\text{mm}$ Any spot/dot/void outside of viewing area is acceptable			
Minor	Protective film tilt	Not fully cover LCD	Reject
Major	COG coating	Not fully cover ITO circuit	Reject

#### 8. Electric Inspection

Defect	Inspection Item	Inspection Standards	
Major	Short		Reject
Major	Open		Reject

## 10. QUALITY SPECIFICATIONS (Continued)

### 10-4. Criteria (Continued)

#### 10. Inspection Specification of LCD

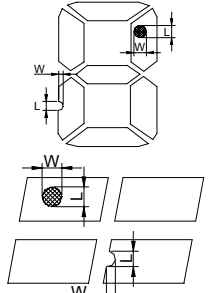
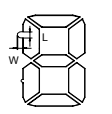
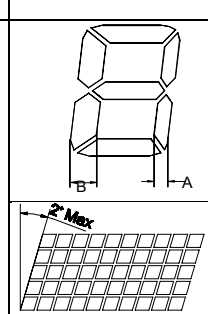
Defect	Inspect Item		Inspection Standards				
			W	$W \leq 0.03$	$0.03 < W \leq 0.05$	$W > 0.05$	
Minor	Linear Defect	* Glass Scratch * Polarizer Scratch * Fiber and Linear material	L	$L < 5$	$L < 3$	Any	
			ACC. NO.	1	1	Reject	
			Note	L is the length and W is the width of the defect			
Minor	Black Spot and Polarizer Pricked	* Foreign material between glass and polarizer or glass and glass * Polarizer hole or protuberance by external force	$\Phi$	$\Phi \leq 0.1$	$0.1 < \Phi \leq 0.15$	$0.15 < \Phi \leq 0.2$	$\Phi > 0.2$
			ACC. NO.	3EA / 100mm <sup>2</sup>	2	1	0
			Note	$\Phi$ is the average diameter of the defect. Distance between two defects > 10mm.			
Minor	White Spot and Bubble in polarizer	* Unobvious transparent foreign material between glass and glass or glass and polarizer * Air protuberance between polarizer and glass	$\Phi$	$\Phi \leq 0.3$	$0.3 < \Phi \leq 0.5$	$0.5 < \Phi$	
			ACC. NO.	3EA / 100mm <sup>2</sup>	1	0	
			Note	$\Phi$ is the average diameter of the defect. Distance between two defects > 10mm.			
Minor	Segment Defect		$\Phi$	$\Phi \leq 0.10$	$0.10 < \Phi \leq 0.20$	$0.20 < \Phi \leq 0.25$	$\Phi > 0.25$
			ACC. NO.	3EA / 100mm <sup>2</sup>	2	1	0
			Note	W is more than 1/2 segment width			
			Note	$\Phi = \frac{L + W}{2}$ Distance between two defect is 10mm			
Minor	Protuberant Segment	 $\Phi = (L + W) / 2$	$\Phi$	$\Phi \leq 0.10$	$0.10 < \Phi \leq 0.20$	$0.20 < \Phi \leq 0.25$	$\Phi > 0.25$
			W	Glue	$W \leq 1/2$ Seg $W \leq 0.2$	$W \leq 1/2$ Seg $W \leq 0.2$	Ignore
			ACC. NO.	3EA / 100mm <sup>2</sup>	2	1	0
Minor	Assembly Mis-alignment		1. Segment				
			B	$B \leq 0.4\text{mm}$	$0.4 < B \leq 1.0\text{mm}$	$B > 1.0\text{mm}$	
			B-A	$B-A < 1/2B$	$B-A < 0.2$	$B-A < 0.25$	
			Judge	Acceptable	Acceptable	Acceptable	
			2. Dot Matrix				
Deformation > 2°				Reject			
Minor	Stain on LCD Panel Surface		Accept when stains can be wiped lightly with a soft cloth or a similar one. Otherwise, judged according to the above items: "Black spot" and "White Spot"				

## 11. RELIABILITY

NO.	Item	Condition	Criterion
1	High Temperature Operating	70°C, 240Hrs	No defect in cosmetic and operational function allowable.
2	Low Temperature Operating	-20°C, 240Hrs	
3	High Humidity	60°C, 90%RH, 96Hrs	
4	High Temperature Storage	80°C, 240Hrs	
5	Low Temperature Storage	-30°C, 240Hrs	
6	Vibration	Random wave 10 ~ 100Hz Acceleration: 2g 2 Hrs per direction(X,Y,Z)	Total current Consumption should be below double of initial value.
7	Thermal Shock	-30°C to 25°C to 80°C (60Min) (5Min) (60Min) 10Cycles	
8	ESD Testing	Contract Discharge Voltage: +1 ~ 5kV and -1 ~ -5kV  Air Discharge Voltage: +1 ~ 8kV and -1 ~ -8kV	There will be discharged ten times at every discharging voltage cycle. The voltage gap is 1kV.

- Note: 1) Above conditions are suitable for GOLDENTEK standard products.  
2) For restrict products, the test conditions listed as above must be revised.

MODEL	LMG1286410A-BMDSWW-NY	22/25	PRODUCT SPECIFICATIONS	REV:3.0
-------	-----------------------	-------	------------------------	---------

## 12. HANDLING PRECAUTION

### (1) Mounting Method

The panel of the LCD Module consists of two thin glass plates with polarizers which easily get damaged since the Module is fixed by utilizing fitting holes in the printed circuit board. Extreme care should be taken when handling the LCD Modules.

### (1) Caution of LCD handling & cleaning

When cleaning the display surface, use soft cloth with solvent (recommended below) and wipe lightly.

- Isopropyl alcohol
- Ethyl alcohol
- Trichloro trifloro thane

Do not wipe the display surface with dry or hard materials that will damage the polarizer surface.

Do not use the following solvent:

- Water
- Ketone
- Aromatics

### (3) Caution against static charge

The LCD Module use C-MOS LSI drivers, so we recommend that you connect any unused input terminal to VDD or VSS, do not input any signals before power is turned on. And ground your body, Work/assembly table. And assembly equipment to protect against static electricity.

### (4) Packaging

- Modules use LCD elements, and must be treated as such. Avoid intense shock and falls from a height.
- To prevent modules from degradation. Do not operate or store them exposed directly to sunshine or high temperature/humidity.

### (5) Caution for operation

- It is indispensable to drive LCD's within the specified voltage limit since the higher voltage than the limit shorten LCD life. An electrochemical reaction due to direct current causes LCD deterioration, Avoid the use of direct current drive.

MODEL	LMG1286410A-BMDSWW-NY	23/25	PRODUCT SPECIFICATIONS	REV:3.0
-------	-----------------------	-------	------------------------	---------



## 12. HANDLING PRECAUTION (Continued)

- Response time will be extremely delayed at lower temperature than the operating temperature range and on the other hand at higher temperature LCD's show dark color in them.

However those phenomena do not mean malfunction or out of order with LCD's. Which will come back in the specified operating temperature range.

- If the display area is pushed hard during operation, some font will be abnormally displayed but it resumes normal condition after turning off once.
- A slight dew depositing on terminals is a cause for electro-chemical reaction resulting in terminal open circuit.

Usage under the relative condition of 40°C, 50%RH or less is reequired.

### (6) Storage

In the case of storing for a long period of time (for instance.) For years) for the purpose or replacement use, The following ways are recommended.

- Storage in a polyethylene bag with sealed so as not to enter fresh air outside in it, And with no desiccant.
- Placing in a dark place where neither exposure to direct sunlight nor light is. Keeping temperature in the specified storage temperature range.
- Storing with no touch on polarizer surface by the anything else. (It is recommended to store them as they have been contained in the inner container at the time of delivery)

### (7) Safety

- It is recommendable to crash damaged or unnecessary LCD into pieces and wash off liquid crystal by using solvents such as acetone and ethanol.

Which should be burned up later.

- When any liquid crystal leaked out of a damaged glass cell comes in contact with your hands, please wash it off well with soap and water.

MODEL	LMG1286410A-BMDSWW-NY	24/25	PRODUCT SPECIFICATIONS	REV:3.0
-------	-----------------------	-------	------------------------	---------

### 13. OUTLINE DIMENSION

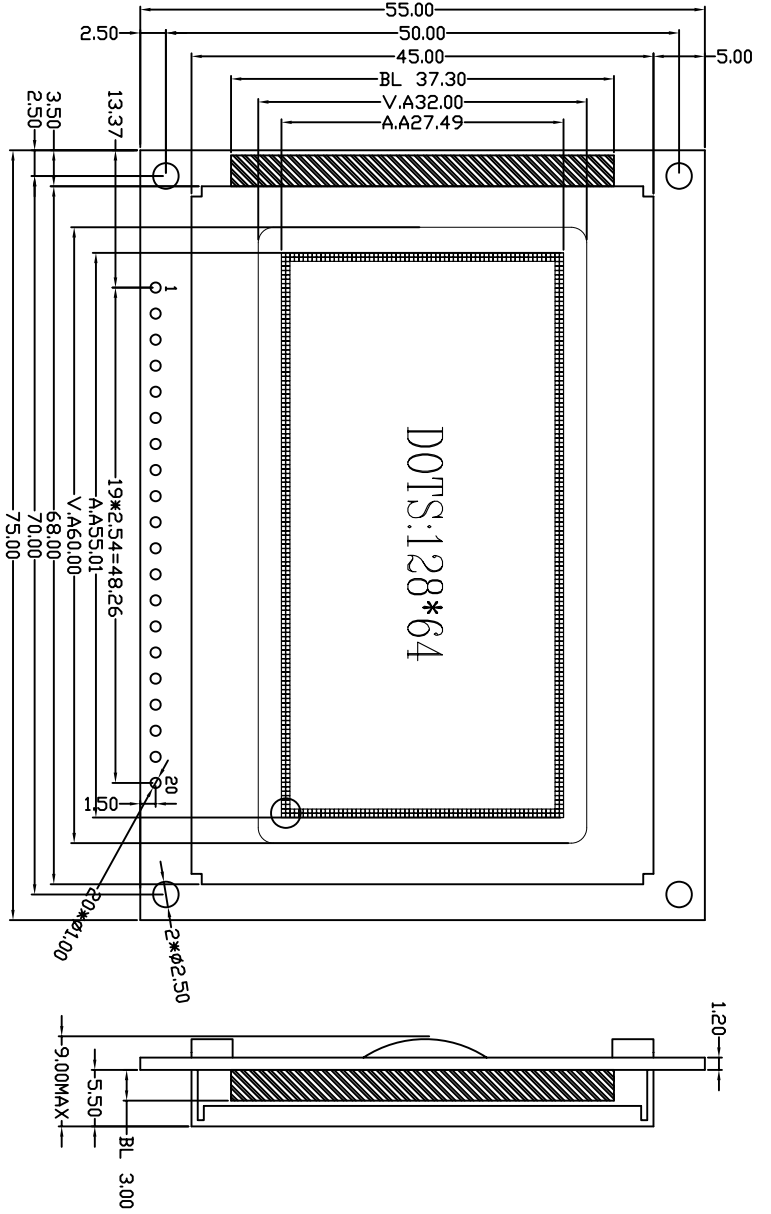

The Tolerance unless classified is  $\pm 0.2\text{mm}$

1	2	3	4	5	6	7	8	9	10	11	12	13	14	15	16	17	18	19	20
VDD	VSS	V0	DB0	DB1	DB2	DB3	DB4	DB5	DB6	DB7	CS2/CS1	RST/R/W	RS	E	VEE	K			A

**NOTES:**

- 1.LCD TYPE: STN / BLUE
- 2.VIEWING ANGLE: 6:00 CLDCK
- 3.POLARIZER MODE: TRANSMISSIVE / NEGATIVE
- 4.OPERATING TEMP:  $-20^{\circ}\text{C}$ -- $+70^{\circ}\text{C}$
- 5.STORAGE TEMP:  $-30^{\circ}\text{C}$ -- $+80^{\circ}\text{C}$
- 6.POWER SUPPLY: +5V,VLCD: 9V
- 7.BACKLIGHT:WHITE LED, 5.0V
- 8.LCD DRIVE MODE: 1/64 DUTY,1/9 BIAS
- 9.LCD DRIVER: SBN0064 & SBN6400
- 10.UNMARKED TOLERANCE:  $\pm 0.2\text{mm}$

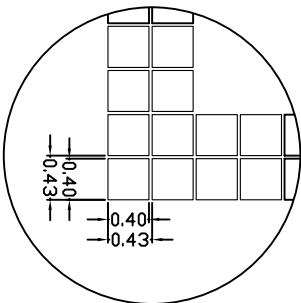

**MODEL**

**LMG1286410A-BMDSWW-NY**

**25/25**

**PRODUCT SPECIFICATIONS**

**REV:3.0**