

4611110000285

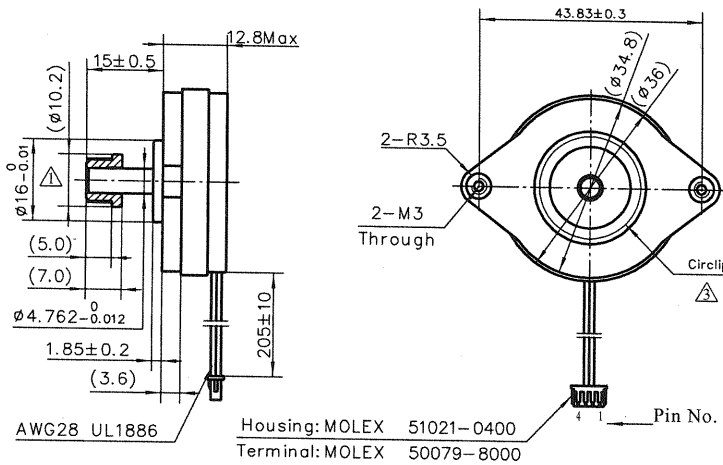
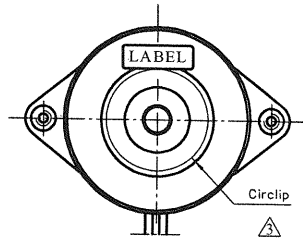

AWG28 UL1886 Housing: MOLEX 51021-0400
Terminal: MOLEX 50079-8000 Pin No.

接线图

Wiring Diagram

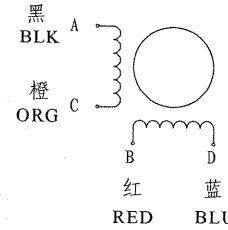

连接器针位 vs. 引线颜色

Pin No. vs. Lead Wire Colour

PIN NO.	颜色 Colour
1	蓝 Blue
2	橙 Orange
3	黑 Black
4	红 Red

励磁顺序 vs. 旋转方向

Exciting Sequence vs. Direction of Rotation

STEP	A	B	C	D	
1	+	+	-	-	CCW
2	-	+	+	-	
3	-	-	+	+	
4	+	-	-	+	CW

从安装面看为顺时针方向

Clockwise view from mounting side

带轮规格 Pulley Specification

齿型 Profile	1.5GT
齿数 Number of teeth	19
节距 Pitch	1.5
节圆 Pitch diameter	Ø9.07
齿顶圆 Outside diameter	Ø8.61±0.05
材料 Material	SMF5030

规格 Specifications

1. 相数 Number of Phase	2
2. 步距角 Step Angle	0.9°
3. 额定电压 Rated Voltage	3.6V DC
4. 额定电流 Rated Current	0.3A
5. 保持力矩 Holding Torque	40mN.m Min. (Two phases on rated current)
6. 相电阻 Phase Resistance	12Ω±10% (20°C)
7. 相电感 Phase Inductance	8mH±20% (1kHz 1V rms)
8. 转子惯量 Rotor Inertia	4g.cm ²
9. 电机重量 Motor Weight	60g
10. 绝缘等级 Insulation Class	B(130°C)

铭牌 LABEL (4:1)



★ Pulley supplied by customer
带轮由客户提供



REV.	版本记录 REVISION RECORD	DATE	UNLESS OTHERWISE SPECIFIED	NAMES	SIGNATURE	DATE	Type: 14HK0402-26N	Rev. D	SCALE 1:1	Sheet 1 of 1
G			Unit: mm	批准 Approve	[Signature]	12.18	MOONS' Hybrid Stepping Motor Shanghai Moons' Electric Co., Ltd.	This document is released for information only. Its reproduction in whole or in part or its dissemination to third parties is prohibited. All trademarks and registered trademarks appearing on this document are the property of their respective owners.		
F			第一角画法 FIRST ANGLE METHOD	标准化 Standard	[Signature]	12.17				
E			未注线性与角度尺寸公差 Tolerances for linear and angular dimensions without individual tolerance indications GB/T 1804-m eqv ISO 2768-1:m	工艺 Technology	[Signature]	12.17				
D	ADD CIRCLIPS	2012.12.15	未注形状与位置尺寸公差 Geometrical tolerance for features without individual tolerance indications GB/T 1184-K eqv ISO 2768-2:K	审核 Check	[Signature]	12.17				
C	LABEL ADD "MADE IN CHINA"	2011.01.14		设计 Design	杨广志	2012.12.15				
B	增加带轮 Add pulley	2010.03.02								
A	原始版本 Original revision	2009.09.22								