



3CO-3345AT32 GNSS G-MOUSE Data Sheet

Revision: 0.2

The3core Co., Ltd.

#936, 122, LS-ro, Dongan-gu, Anyang-si, Gyeonggi-do, Korea

Tel: +82-(0)31-347-9998 / Fax: +82-(0)31-347-9993 / Email: mackyun@the3core.com

Table of Contents

1. Introduction.....	3
1.1 Overview	3
1.2 Features	3
1.3 System Block	4
1.4 Product Applications	4
2. Technical Specifications	5
2.1 Specification List.....	5
3. Hardware interface	6
3.1 Pin Configuration.....	6
3.2 Pin Assignment.....	6
3.3 Cable specification.....	7
4. NMEA Output Sentences.....	8
4.1 NMEA Protocol overview.....	8
5. Outline drawing	15
6. Contact Information Section	16

1. Instruction

1.1 Overview

The G-MOUSE suitable for integration in variety of consumer devices such as PDA, Personal Navigation Device, Digital Camera Vehicle Navigation, Telematics and other applications requiring Position, Velocity and Time. High Sensitivity GNSS technology provides unprecedented indoor and outdoor positioning capability including urban canyon and under thick foliage. provides standard NMEA output for compatibility with all user applications, and map engines.

1.2 Features

- * AT6558R-5N32 GNSS Chip
- * Active jammer detection and reduction
- * Multi-path detection and compensation
- * DGPS(WAAS/EGNOS/MSAS/GAGAN) QZSS support
- * Support SBAS
- * Update Rate: 1Hz (max up to 5Hz)
- * RoHS compliant
- * NMEA-0183 compliant protocol or custom protocol

1.3 System Block Diagram

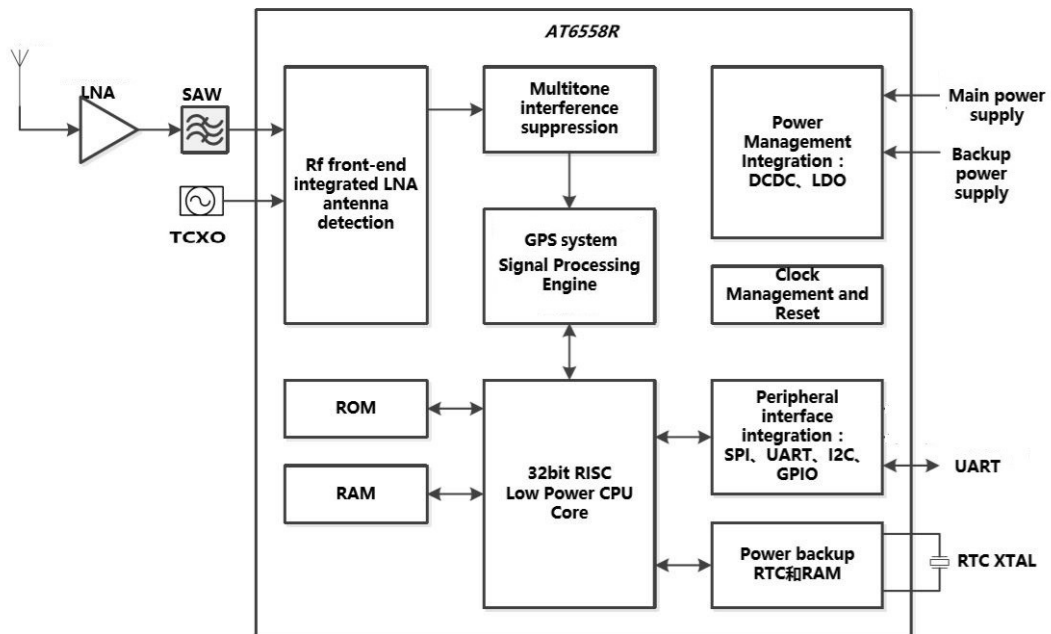

1.4 Product Applications

- * GNSS receiver application
- * Automotive application
- * Car navigations and tracking
- * Aviation application
- * Ideal for PDA, Pocket PC and other consumer devices requiring positioning capability

2. Technical Specifications

2.1 Specification List

Frequency	GPS L1, 1575.42MHz GLONASS L1, 1598.0625~1609.3125MHz
Electrical Interface	Full duplex serial communications
Baud rate	9,600bps(Default) / (max up to 5Hz)
Update rate	1Hz(Default)
Position	2.5m (Autonomous) / 2.0m SBAS(CEP50%)
Velocity	0.1 m/s
Time	1PPS
Hot start	<1sec., Autonomous
Cold start	<32sec., Autonomous
Tracking Sensitivity	-162dBm, typical
Acquisition sensitivity	-148dBm Autonomous cold start
Reacquisition	-160dBm, typical
Operation current	50mA_Tracking
Backup current	8uA
Altitude	50,000m
Velocity	500m/s
Acceleration	4g
Jerk	1g/s
Power Supply Voltage	+ 5V
Backup Voltage	+ 1.4 ~ + 3.6V
Dimension	33.0 x 45.0 x 11.5mm(±0.2mm)

3. Hardware interface

3.1 Pin Configuration

The 3CO-3345AT32 External pin connection is presented in the figure below.

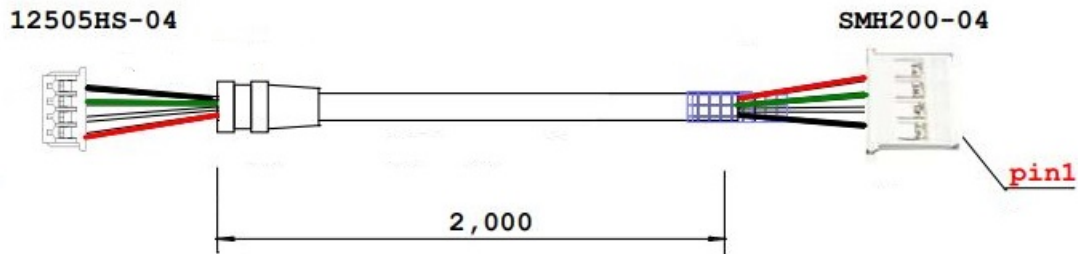

Pin configurations

1.25pin	Name	Description	Colorcode	Remark	2.00mm4p
1	GND	G	BLACK	GND	1
2	RXD	IN	GREEN	IN	3
3	TXD	DATA OUT	WHITE	OUT	2
4	VCC	+5.0V	RED	POWER	4

3.2 Pin Assignment

Pin	Signal Name	I/O	Description
1	GND	G	Ground
2	TXD	O	UART Serial Data Output
3	RXD	I	UART Serial Data Input
4	VCC	I	DC power Input

VCC

This is the main DC power supply input pin. IT provides voltage to module.

TXD

This is the main transmitting channel and is used to output navigation and measurement data to debug software or user written software.

RXD

This is the main receiver channel and is used to receive software commands to the board from debug software or from user written software.

GND

GND provides the ground.

4. NMEA Output Sentences

NMEA messages sent by the GNSS receiver are based on the NMEA 0183 Version 4.10

The following picture shows the structure of a NMEA protocol message.

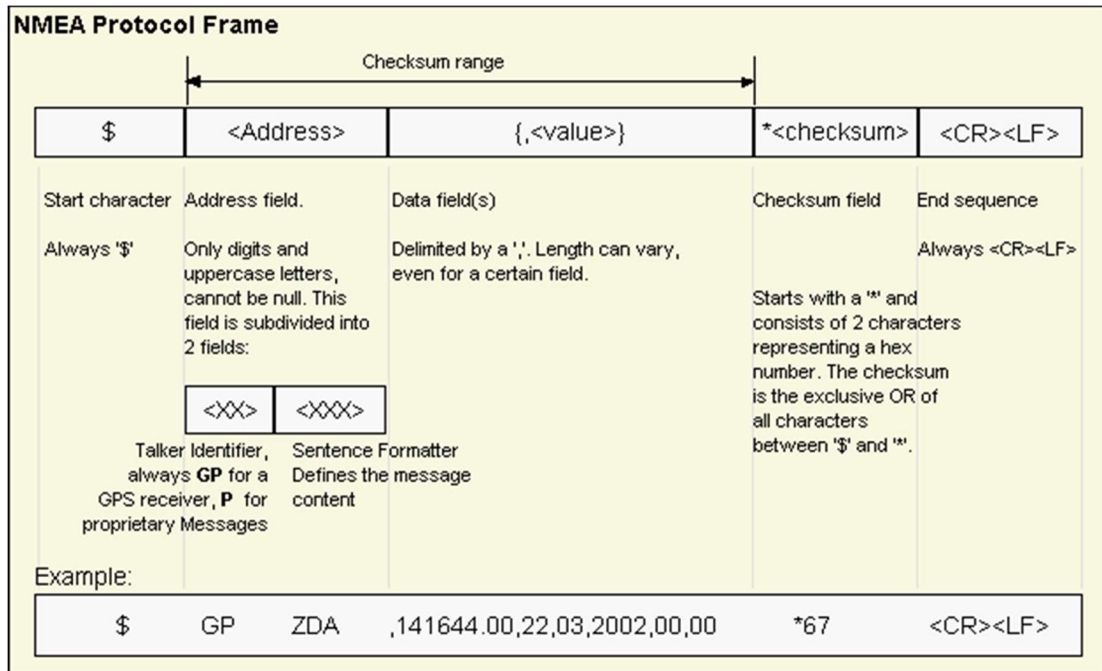

For further information on the NMEA Standard please refer to NMEA 0183 Standard

For Interfacing Marine Electronic Devices, Version 2.30, March 1, 1998. See <http://www.nmea.org/> for ordering instructions.

The NMEA standard allows for proprietary, manufacturer-specific messages to be added. These shall be marked with a manufacturer mnemonic.

GGA Time, position and fix type data.

FORMAT	\$--GGA,hhmmss.ss,llll.ll,a,yyyyy.yy,a,x,xx,x.x,x.x,M,x.x,M,x.x,xxxx*hh<CR><LF>	
NO.	Symbol	Description
1	\$--GGA	BDS only mode: BDGGA GPS only mode: GPGGA GLONASS only mode: GLGGA dual mode: GNGGA
2	hhmmss.ss	Time (UTC)
3	llll.ll	Latitude
4	a	N or S (North or South)
5	yyyyy.yy	Longitude
6	a	E or W (East or West)
7	x	0 - fix not available, 1 - GNSS fix, 2 - Differential GNSS fix
8	xx	Number of satellites used for fix
9	x.x	HDOP
10	x.x	Antenna Altitude above/below mean-sea-level (geoid)
11	M	Units of antenna altitude, meters
12	x.x	Geoidal separation, the difference between the WGS-84 earth ellipsoid and mean-sea-level (geoid), "-" means mean-sea-level below ellipsoid
13	M	Units of antenna altitude, meters
14	x.x	Age of differential GNSS data, time in seconds, null field when DGNSS is not used
15	xxxx	Differential reference station ID, 0000-1023
16	hh	Checksum

GLL Latitude and longitude, with time of position fix and status

<i>Field No.</i>	<i>Example</i>	<i>Format</i>	<i>Name</i>	<i>Unit</i>	<i>Description</i>
0	\$-GLL	String	\$GNGLL	-	Message ID, GLL protocol header
1	4717.11364	ddmm.mmmm	Latitude	-	Latitude, Degrees + minutes, see Format description
2	N	Character	N	-	N/S Indicator, hemisphere N=north or S=south
3	00833.91565	dddmm. Mmmm	Longitude	-	Longitude, Degrees + minutes, see Format description
4	E	Character	E	-	EW indicator, E=east or W=west
5	092321.00	hhmmss.sss	hhmmss.ss	-	UTC Time, Current time
6	A	Character	Valid	-	V = Data invalid or receiver warning, A = Data valid. See Position Fix Flags description
<i>Start of optional block</i>					
7	A	Character	Mode	-	Positioning Mode, see Position Fix Flags description
<i>End of optional block</i>					
7	*60	hexadecimal	cs	-	Checksum

GSA GNSS DOP and Active satellites

FORMAT	\$--GSA,a,x,xx,xx,xx,xx,xx,xx,xx,xx,xx,xx,xx,x.x,x.x,x.x,h*hh<CR><LF>	
NO.	Symbol	Description
1	\$--GSA	BDS only mode: BDGSA GPS only mode: GPGSA GLONASS only mode: GLGSA dual mode: GNGSA
2	a	M: manual 2D or 3D mode A: auto 2D/3D mode select
3	x	1: not fix 2: 2D fix 3: 3D fix
4	xx	ID of 1st satellite used for fix GPS PRN: 1~32 SBAS PRN: 33~64 GLONASS PRN: 65~96 BDS PRN: 1~37
5	xx	ID of 2nd satellite used for fix
...
15	xx	ID of 12th satellite used for fix
16	x.x	PDOP
17	x.x	HDOP
18	x.x	VDOP
19	h	GNSS system identification 1: GPS 2: GLONASS 4: BDS
20	hh	Checksum

GSV GNSS Satellites in View

FORMAT	\$--GSV,x,x,xx,xx,xx,xxx,xx.....xx,xx,xxx,xx,h*hh<CR><LF>	
NO.	Symbol	Description
1	\$--GSV	BDS satellite: BDGSV GPS satellite: GPGSV GLONASS satellite: GLGSV
2	x	total number of messages
3	x	message number
4	xx	satellites in view
5	xx	satellite ID
6	xx	elevation in degrees
7	xxx	azimuth in degrees
8	xx	SNR in dB
...	...	more satellite infos like NO. 5~8
penultimate	h	reserved, default 0
last	hh	Checksum

RMC Recommended Minimum data

FORMAT	\$--RMC,hhmmss.ss,A,llll.ll,a,yyyyy.yy,a,x.x,x.x,xxxxx,x.x,x.x,a,a*hh<CR><LF>	
NO.	Symbol	Description
1	\$--RMC	BDS only mode: BDRMC GPS only mode: GPRMC GLONASS only mode: GLRMC dual mode: GNRMC
2	hhmmss.ss	Time (UTC)
3	A	A: fix V: not fix
4	llll.ll	Latitude
5	a	N or S (North or South)
6	yyyyy.yy	Longitude
7	a	E or W (East or West)
8	x.x	speed over ground, knots
9	x.x	speed over ground angle, degrees
10	xxxxx	Date, ddmmyy
11	x.x	magnetic variation angle, degrees
12	x.x	magnetic variation, E or W (East or West)
13	a	A: GNSS fix D: Differential GNSS fix E: DR fix N: not fix
14	a	navStatus Note: NMEA v4.10 and above only
16	hh	Checksum

VTG Course over ground and Ground speed

FORMAT	\$--VTG,x.x,T,x.x,M,x.x,N,x.x,K,a*hh<CR><LF>	
NO.	Symbol	Description
1	\$--VTG	BDS only mode: BDVTG GPS only mode: GPVTG GLONASS only mode: GLVTG dual mode: GNVTG
2	x.x	Course over ground, degrees true north
3	T	true north
4	x.x	Course over ground, degrees magnetic
5	M	magnetic
6	x.x	Speed over ground, knots
7	N	knots
8	x.x	Speed over ground, km/h
9	K	km/h
10	a	A: GNSS fix D: Differential GNSS fix E: DR fix N: not fix
11	hh	Checksum

ZDA Time and date

FORMAT	\$--ZDA,hhmmss.ss,xx,xx,xxxx,xx,xx*hh<CR><LF>	
NO.	Symbol	Description
1	\$--ZDA	BDS only mode: BDZDA GPS only mode: GPZDA GLONASS only mode: GLZDA dual mode: GNZDA
2	hhmmss.ss	Time (UTC)
3	xx	Day (UTC)
4	xx	Month (UTC)
5	xxxx	Year (UTC)
6	xx	fixed to 00
7	xx	fixed to 00
8	hh	Checksum

TXT Antenna Detection Sentence

Example:

\$GPTXT,01,01,01,ANTENNA OPEN*25

5. Outline drawing

Dimension: (Unit: mm, Tolerance: +/- 0.2mm)

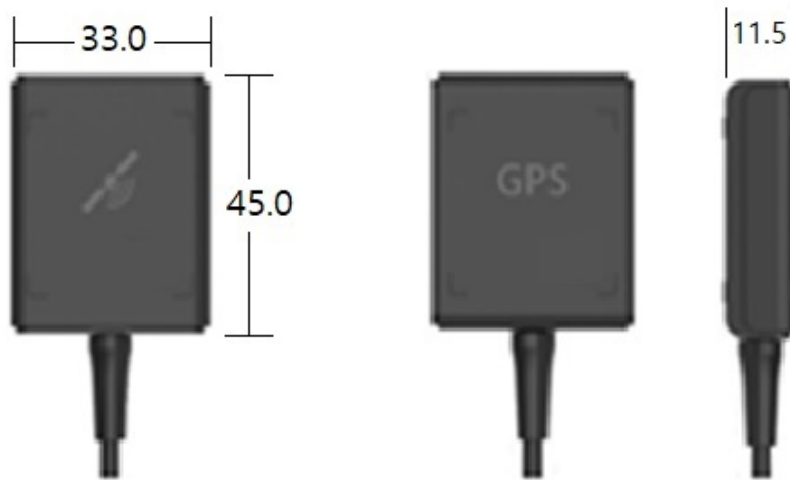



6. Contact Information Section

Address: #936, 122, LS-ro, Dongan-gu, Anyang-si, Gyeonggi-do, Korea

Tel: +82-(0)31-347-9998

Fax: +82-(0)31-347-9993

E-Mail: Mackyun@the3core.com